

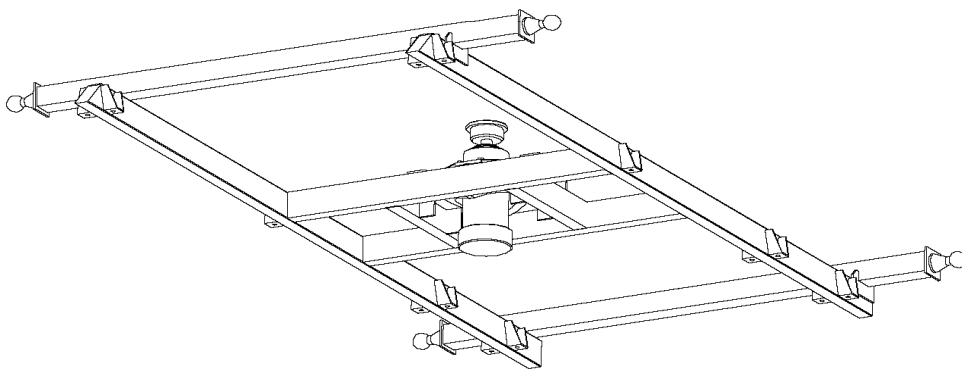

**LIGHT WEIGHT TIPPER BODY SET**

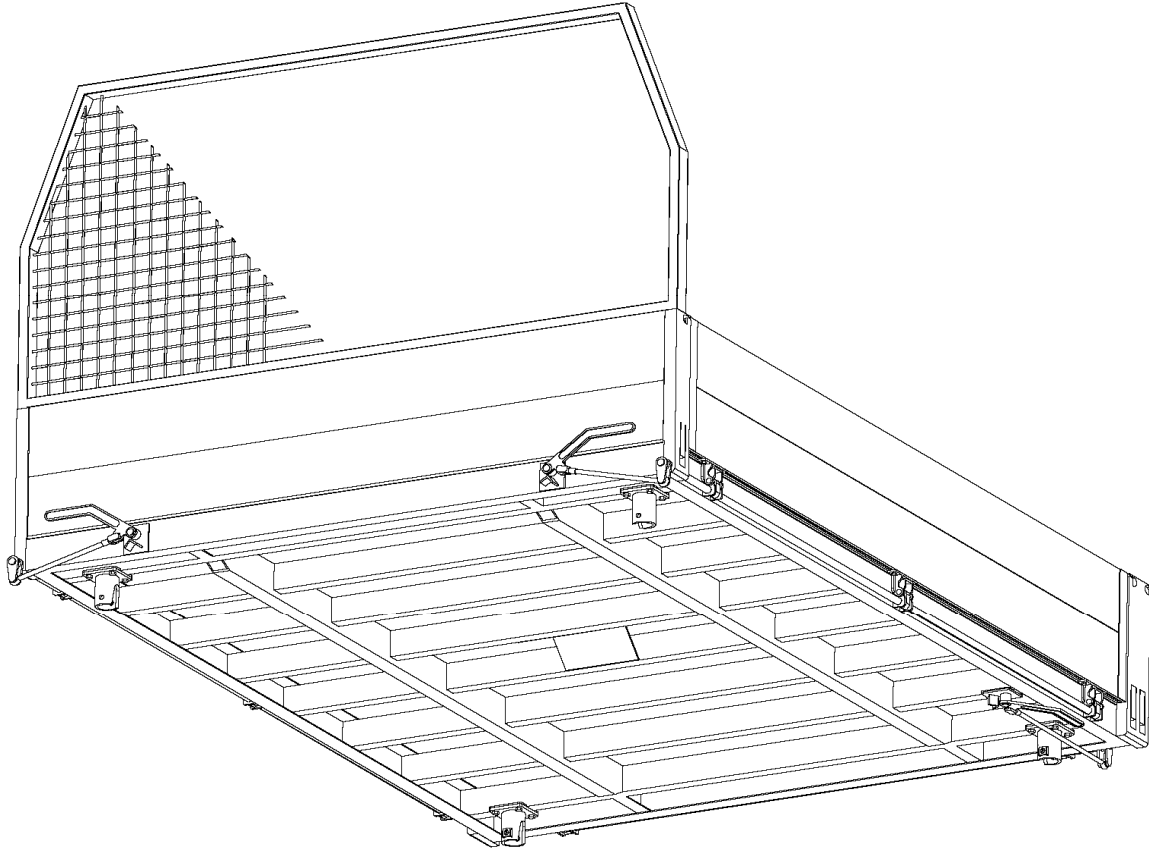



**Characteristics:**

- a. for trucks total weight 3,5t pay load ~ 2t
  - b. for trucks total weight 7,5t pay load ~ 5t
- Side boards high 400-500-600 mm, of aluminum or steel

**Drive:**

Hydraulic power unit with electric command  
Hydraulic system kit with telescopic cylinder  
Side opening ( two lateral and one rear) down or combination down -up  
Opening the rear side manual or automatic

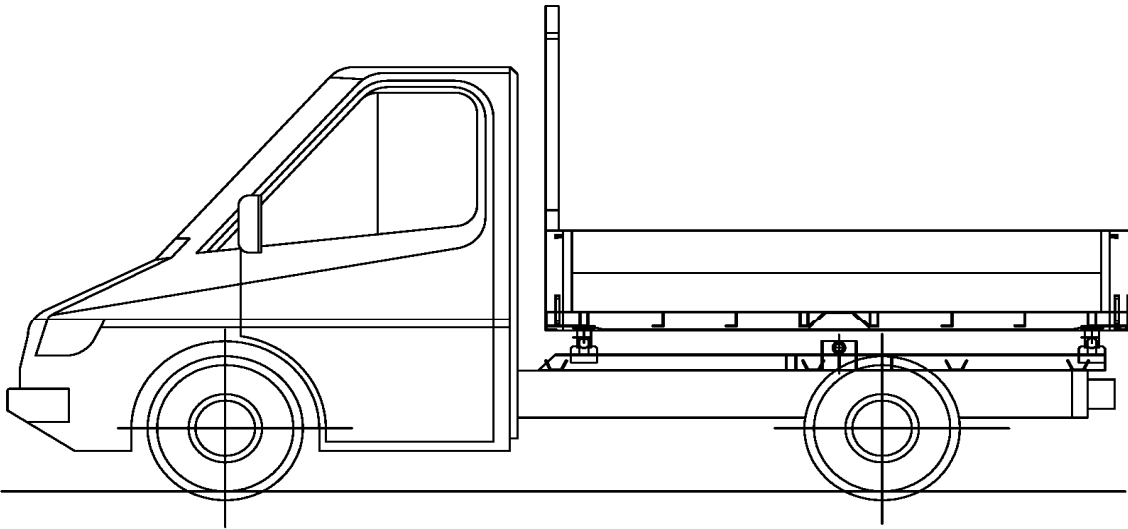
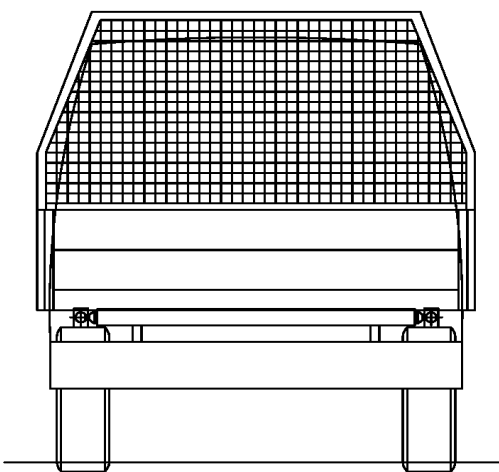
**Front side option with cab protection**

Front side with net protection

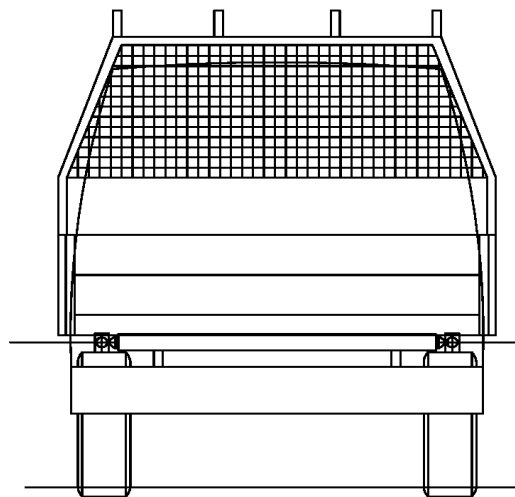
Front side with console  
for tube transport

Side opening options

Opening the rear side down

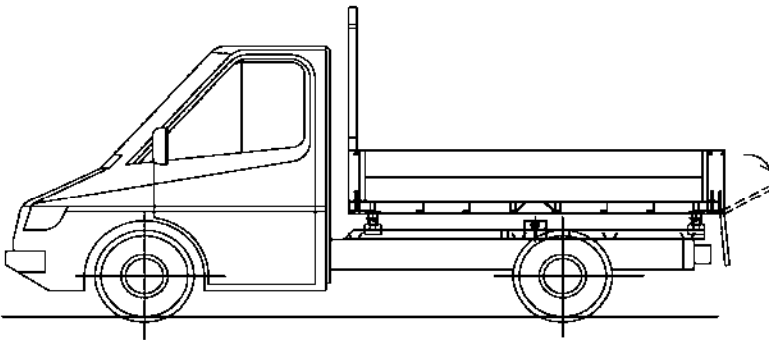

Opening the lateral side down

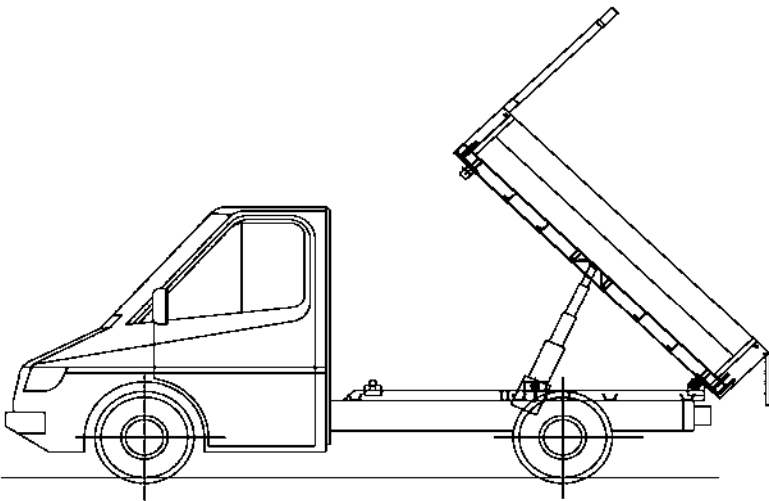
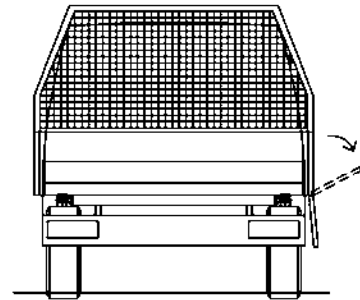

Opening the rear side up

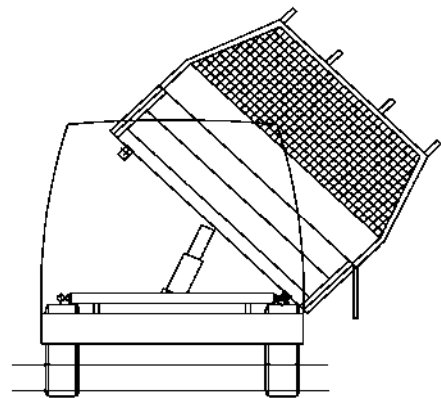

Opening the lateral side up

1. tipping hinge in case of combined opening up-down
2. TIR hinge in case of opening down

