

TELESZKÓPOS MUNKAHENGEREK
CILINDRI TELESCOPICI
TELESCOPIC CYLINDERS
TELESKOPZILINDER

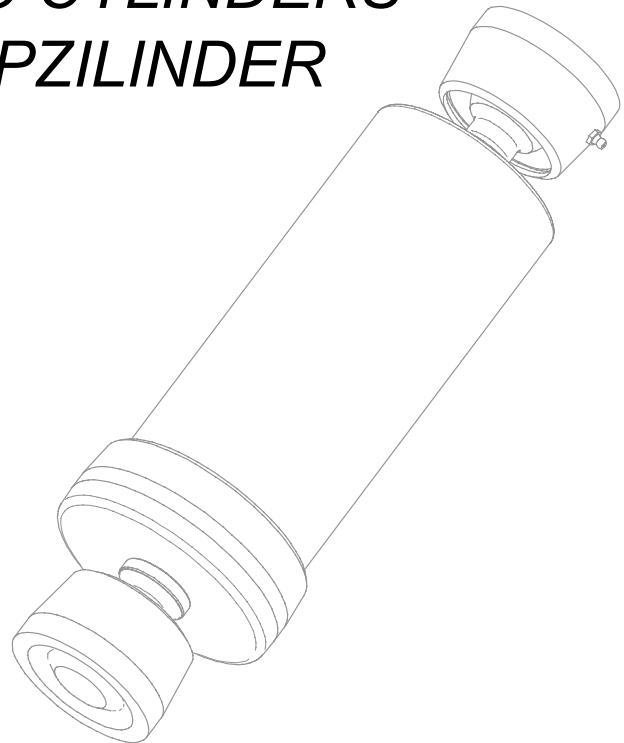

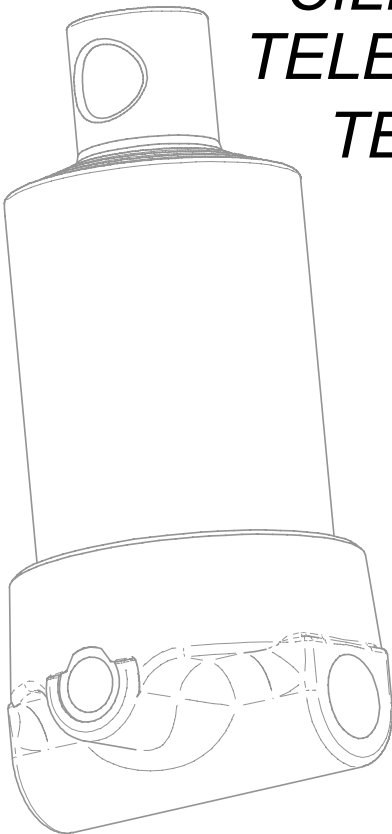

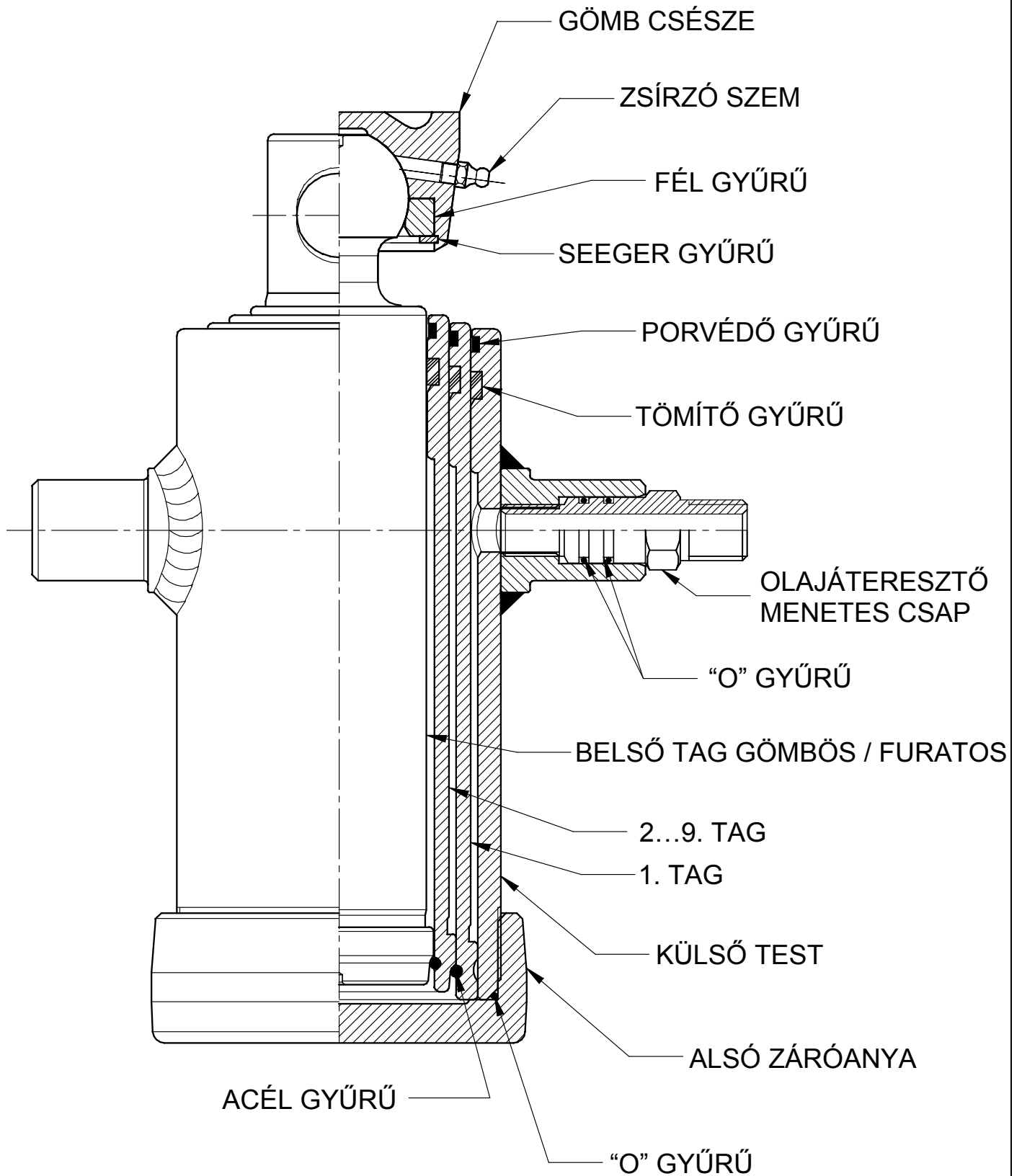
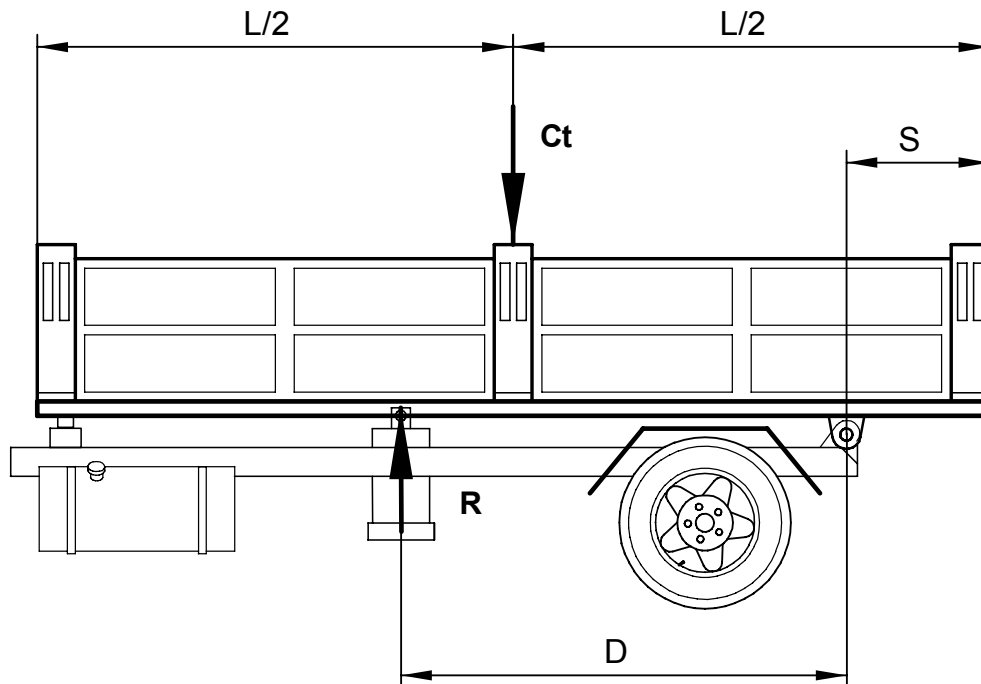

$$R = \frac{Ct \cdot \left(\frac{L}{2} - S \right)}{D}$$

R = Portata cilindro
L = Lunghezza cassone
S = Lunghezza parte a sbalzo
Ct = Carico utile + peso cassone
D = Distanza tra perno di ribaltamento e cilindro

R = Cylinder capacity
L = Dump body length
S = Length of cantilever section
Ct = Working load + weight of body
D = Distance between tip-up pin and cylinder

R = Munkahenger teherbírása
L = Felépítmény hossza
S = Felépítmény túlnyúlása
Ct = Hasznos terhelés + felépítmény tömege
D = Billenő forgáspont és a munkahenger távolsága

R = Zylinder-Hubkraft
L = Länge Kippaufbau
S = Überstandlänge
Ct = Nutzlast + Gewicht Kippaufbau (Tank)
D = Abstand Kippstift/Zylinderbefestigung

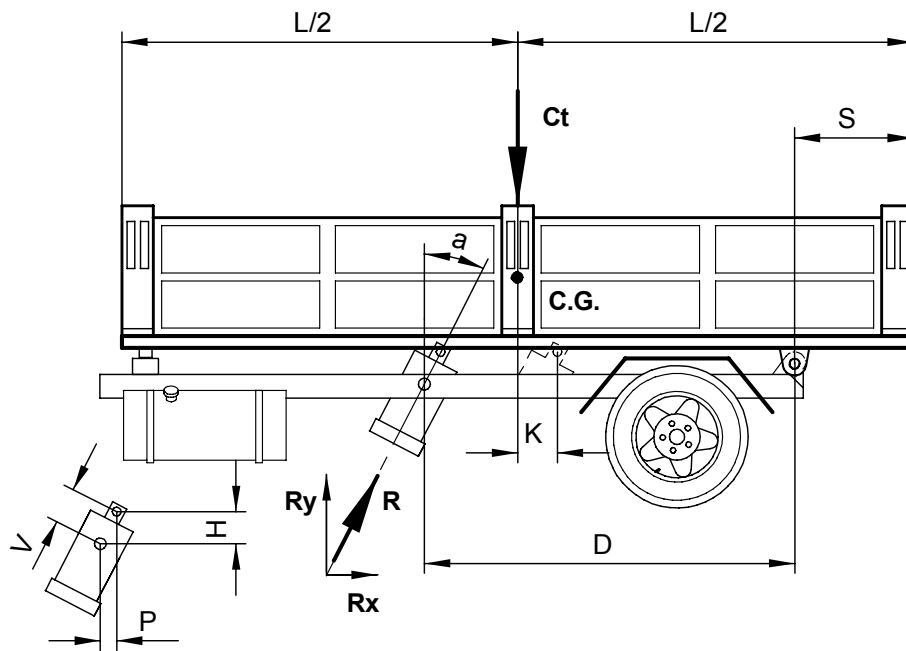

$$a \leq 30^\circ ; K = 100mm \text{ max. } a \text{ dx C.G.} ; R = \left(\frac{L}{2} - S \right) \cdot \frac{Ct \cdot V}{D \cdot H} ; R_x = R \cdot \frac{P}{V}$$

R =	Portata cilindro	R =	Capacité de charge vérin
Ry =	Forza orizzontale sul perno	Ry =	Force horizontale sur l'axe
Rx =	Forza verticale utile	Rx =	Force verticale utile
L =	Lunghezza cassone	L =	Longueur caisson
S =	Lunghezza parte a sbalzo	S =	Longueur partie en porte-à-faux
Ct =	Carico utile + peso cassone	Ct =	Charge utile + poids caisson (citerne)
D =	Distanza tra perno di ribaltamento e cilindro	D =	Distance entre pivot de renversement e vérin
V =	Distanza assiale attacchi cilindro	V =	Distance axiale fixations du vérin
H =	Distanza verticale attacchi cilindro	H =	Distance verticale fixations du vérin
P =	Distanza orizzontale attacchi cilindro	P =	Distance horizontale fixations du vérin
R =	Munkahenger teherbírása	R =	Zylinder-Hubkraft
Ry =	Vízszintes erő a csapon	Ry =	Horizontalkraft auf der Stift
Rx =	Hasznos függőleges erő	Rx =	Vertikale Nutzkraft
L =	Felépítmény hossza	L =	Länge Kippaufbau
S =	Felépítmény túlnyúlása	S =	Überstandlänge
Ct =	Hasznos terhelés + felépítmény tömege	Ct =	Nutzlast + Gewicht Kippaufbau (Tank)
D =	Billenő forgáspont és a munkahenger távolsága	D =	Abstand Kippstift/Zylinderbefestigung
V =	Munkahenger rögzítések axiális távolsága	V =	Achsabstand Zylinderbefestigungen
H =	Munkahenger rögzítések függőleges távolsága	H =	Höhenabstand Zylinderbefestigungen
P =	Munkahenger rögzítések vízszintes távolsága	P =	Horizontalabstand Zylinderbefestigungen

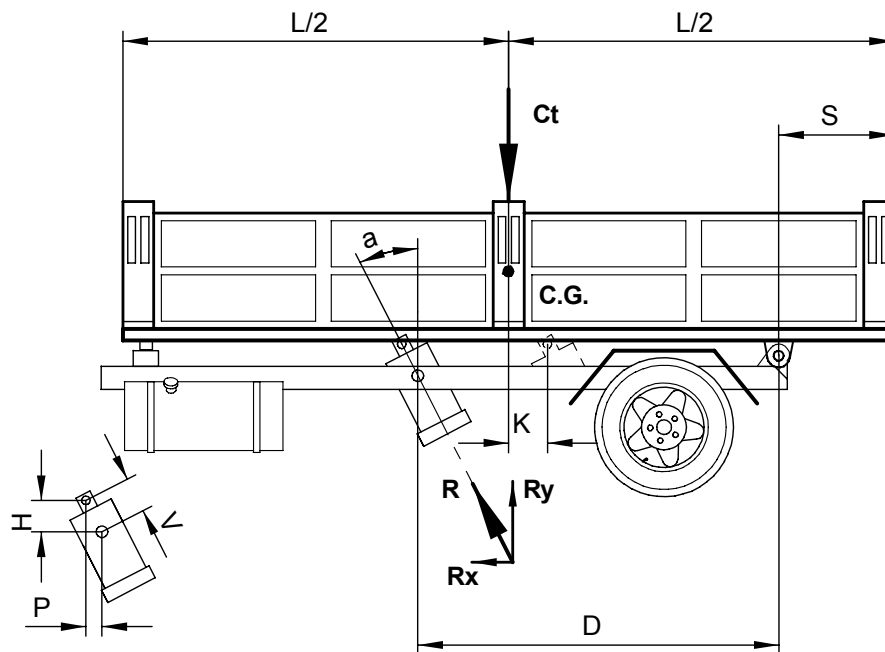

$$a \leq 30^\circ ; K = 100mm \text{ max. } a \text{ dx C.G. ; } R = \left(\frac{L}{2} - S \right) \cdot \frac{Ct \cdot V}{D \cdot H} ; R_x = R \cdot \frac{P}{V}$$

R =	Portata cilindro	R =	Capacité de charge vérin
Ry =	Forza orizzontale sul perno	Ry =	Force horizontale sur l'axe
Rx =	Forza verticale utile	Rx =	Force verticale utile
L =	Lunghezza cassone	L =	Longueur caisson
S =	Lunghezza parte a sbalzo	S =	Longueur partie en porte-à-faux
Ct =	Carico utile + peso cassone	Ct =	Charge utile + poids caisson (citerne)
D =	Distanza tra perno di ribaltamento e cilindro	D =	Distance entre pivot de renversement e vérin
V =	Distanza assiale attacchi cilindro	V =	Distance axiale fixations du vérin
H =	Distanza verticale attacchi cilindro	H =	Distance verticale fixations du vérin
P =	Distanza orizzontale attacchi cilindro	P =	Distance horizontale fixations du vérin
R =	Munkahenger teherbírása	R =	Zylinder-Hubkraft
Ry =	Vízszintes erő a csapon	Ry =	Horizontalkraft auf der Stiff
Rx =	Hasznos függőleges erő	Rx =	Vertikale Nutzkraft
L =	Felépítmény hossza	L =	Länge Kippaufbau
S =	Felépítmény túlnyúlása	S =	Überstandlänge
Ct =	Hasznos terhelés + felépítmény tömege	Ct =	Nutzlast + Gewicht Kippaufbau (Tank)
D =	Billenő forgáspont és a munkahenger távolsága	D =	Abstand Kippstift/Zylinderbefestigung
V =	Munkahenger rögzítések axiális távolsága	V =	Achsabstand Zylinderbefestigungen
H =	Munkahenger rögzítések függőleges távolsága	H =	Höhenabstand Zylinderbefestigungen
P =	Munkahenger rögzítések vízszintes távolsága	P =	Horizontalabstand Zylinderbefestigungen

TABELLA DELLA PORTATA DI SOLLEVAMENTO DELLE SINGOLE SFILATE
 TABLE OF LIFTING CAPACITY OF INDIVIDUAL EXTENSIONS LENGTHS
 TÁBLÁZAT A TAGOK TEHERBÍRÁSI KÉPESSÉGÉRŐL
 TABELLE FÜR TRAGFÄHIGKEIT AN DEN EINZELNEN AUSFAHRSTADIEN

PRESSIONE Bars PRESSION Bars NYOMÁS Bar DRUCKWERTE Bars	SFILATE – EXPANSIONS – TAGOK – STUFEN													
	Ø 46	Ø 61	Ø 68	Ø 76	Ø 88	Ø 91	Ø 107	Ø 126	Ø 145	Ø 165	Ø 187	Ø 210	Ø 236	Ø 265
100	1,6	2,9	3,6	4,5	6	6,5	8,9	12,4	16,5	21,3	27,4	34,6	43,7	55,1
125	2	3,6	4,5	5,6	7,6	8,1	11,2	15,5	20,6	26,7	34,3	43,3	54,7	68,9
160	2,6	4,6	5,8	7,2	9,7	10,4	14,3	19,9	26,4	34,2	43,9	55,5	69,9	88,2
180	2,9	5,2	6,5	8,1	10,9	11,7	16,1	22,4	29,7	38,4	49,4	62,3	78,7	99,2
PORTATA IN TON. – CHARGE IN TON. – TEHERBÍRÁS TONNÁBAN – BALASTBARKEIT IN TON.														

TABELLA DELLA CORSA NECESSARIA PER INCLINARE IL CASSONE AL VALORE VOLUTO
 TABLE OF STROKE NECESSARY TO TILT THE BODY AT REQUIRED DEGREE
 TÁBLÁZAT A SZÜKSÉGES LÖKETHOSSZ KISZÁMÍTÁSÁHOZ ADOTT BILLENÉSI SZÖG MELLETT
 TABELLE FÜR DEN NOTWENDIGEN HUB FÜR DIE NEIGUNG DER PRITSCHEN AUF DEN GEWÜNSCHTEN WERT

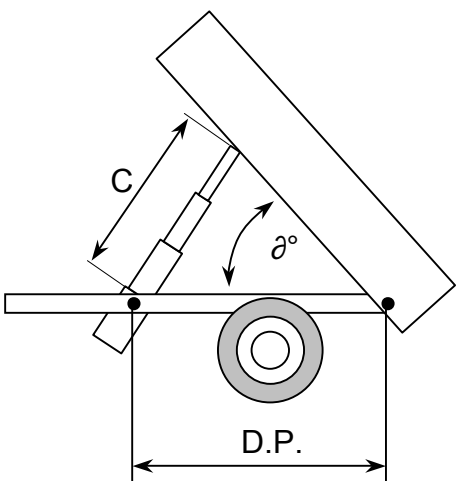
	DP = mm.	C = mm.				
		40°	45°	50°	55°	60°
	800	547	612	676	739	800
	900	616	689	761	831	900
	1000	684	765	845	923	1000
	1200	821	918	1014	1108	1200
	1400	958	1072	1183	1293	1400
	1600	1094	1225	1352	1478	1600
	1800	1231	1378	1521	1662	1800
	2000	1368	1531	1690	1847	2000
	2200	1505	1684	1860	2032	2200
	2400	1642	1837	2029	2216	2400
	2600	1779	1990	2198	2401	2600
	2800	1915	2143	2367	2586	2800
	3000	2052	2296	2536	2770	3000
	3200	2189	2449	2705	2955	3200
	3400	2326	2602	2874	3140	3400
	3600	2463	2755	3043	3325	3600
	3800	2599	2908	3212	3509	3800
	4000	2736	3061	3381	3694	4000
	4200	2873	3215	3550	3879	4200
	4400	3010	3368	3719	4063	4400
	4600	3147	3521	3888	4248	4600
	4800	3283	3674	4057	4433	4800
	5000	3420	3827	4226	4617	5000
	5200	3557	3980	4395	4802	5200
	5400	3694	4133	4564	4987	5400
	5600	3831	4286	4733	5172	5600
	5800	3967	4439	4902	5356	5800
	6000	4104	4592	5071	5541	6000

D.P. = Distanza tra perno cilindro e perno ribaltamento in mm.
 θ° = Inclinazione cassone
 C = Corsa del cilindro in mm.

D.P. = Distance between cylinder pin and tipping pin in mm.
 θ° = Inclination of dump body
 C = Cylinder stroke in mm.

D.P. = Távolság a munkahenger és a felépítmény csapja között
 θ° = Billentés szöge
 C = Munkahenger lökete mm

D.P. = Abstand zwischen zylinderzapfen und kippzapfen in mm.
 θ° = Pritschenneigung
 C = Zylinderhub in mm.

PESO DEI MATERIALI (Kg/m ³)		KÜLÖNBÖZŐ ANYAGOK FAJSÚLYA (Kg/m ³)		
TABLE OF THE WEIGHT (Kg/m ³)		GEWICHT VON DEM MATERIAL (Kg/m ³)		
Materiale	Type	Anyag	Material	Kg/m ³
Argilla, ghiaia (asciutte)	Clay, garvel (dry)	Föld-kavics (száraz)	Ton, Kies (trocken)	1800
Argilla, ghiaia (bagnate)	Clay, garvel (wet)	Föld-kavics (nedves)	Ton, Kies (nass)	2000
Barbabietole	Beet	Cukorrépa	Beete	570/650
Calce grassa (cotta e polverosa)	Lime	Mész (oltatlan)	Kalk	500
Calcestruzzo con calcare	Concrete	Beton+kalcium-karbonát	Kalkbeton	2000
Calcestruzzo con granito	Heavy concrete	Beton+gránit	Beton mit Granit	2200
Calcestruzzo con rottame di mattoni	Transit mix concrete	Beton+tégla maradék	Beton mit Ziegeln	1800
Carbone di legno forte	Charcoal	Szén	Holzkohle	220
Catrame	Tar	Kátrány	Teer	1300
Cemento (sciolto)	Cement	Cement	Zement	1400
Cemento cellulare	Cellular cement	Cement cellular	Zellzement	500/1200
Erba fresca sciolta	Herb, Grass	Fű	Gras	250/350
Fieno sciolto	Hay	Széna	Heu	40/60
Fieno di 6 mesi in fienile	6 month hay (dry)	Széna 6 hónapos	Heu von 6 Monaten	80/100
Fieno pressato	Press hay	Széna préselt	Heu gepresst	200/350
Frumento	Wheat	Búza	Weizen	400/600
Liquame, guano	Guano	Guano	Guano	750/950
Legno di abete bianco (in ciocchi)	Fir wood	Lucfenyő	Fichtenholz	340
Legno di faggio (in ciocchi)	Beech wood	Bükk	Buchenholz	400
Legno di quercia (in ciocchi)	Oak wood	Tölgy	Eichenholz	420
Letame fresco	Manure (fresh)	Friss trágya	Mist (frisch)	200/300
Letame maturo	Manure (old)	Érett trágya	Mist (alt)	450/650
Lignite (mattonelle in mucchio)	Lignite	Lignit	Lignit	720
Malta (calce e sabbia)	Lime Mortar	Malter	Mörtel	1700/1800
Mattoni ordinari	Brick	Tégla hagyományos	Ziegels	1300
Mele	Apples	Alma	Äpfel	300
Neve fresca	Snow	Friss hó	Neuschnee	80/190
Neve acquosa	Wet snow	Latyak	Wässrigeschnee	200/800
Paglia sciolta	Straw	Szalma	Stroh	30/45
Paglia pressata	Press straw	Préselt szalma	Stroh gepresst	100/200
Patate	Potatoes	Krumpli	Kartoffeln	650/750
Pere e prugne	Pears and plums	Körte-szilva	Birnen	350
Pietra da calce (calcare)	Stone	Mészkö	Kalkstein	2000
Sabbia asciutta	Sand (dry)	Homok (száraz)	Sand (trocken)	1600
Sabbia bagnata	Sand (wet)	Homok (vizes)	Sand (nass)	2100
Sale	Salt	Só	Salz	780
Salgemma macinato	Halite	Kősó	Steinsalz	1015
Torba asciugata all'aria	Peat (dry)	Száraz tőzeg	Torf (trocken)	325/410
Torba umida	Peat (wet)	Nedves tőzeg	Torf (nass)	550/650
Tufo (macinato)	Tuff	Tufa	Tuff	950

CILINDRI TELESCOPICI CON 4 SFILATE
TELESCOPIC CYLINDERS WITH 4 EXTENSIONS

TELESZKÓPOS MUNKAHENGER 4 TAGÚ
TELESKOPZYLINDER MIT 4 VERLÄNGERUNGEN

TYPE F :
FORO
FURATOS
HOLE
LOCH

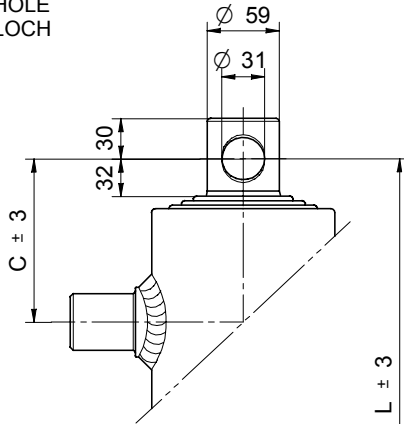

TYPE S :
SFERA
GÖMBÖS
BALL
KUGEL

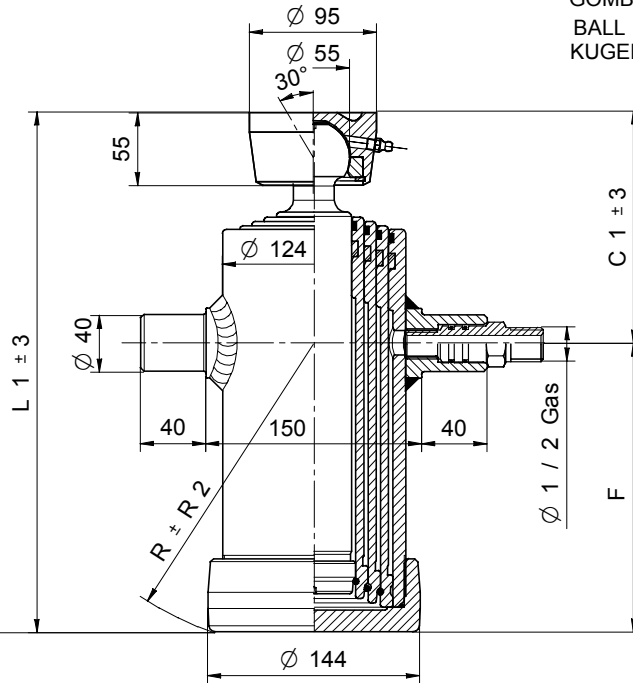

OPCIÓK

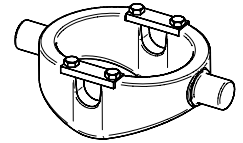

CULLA 3

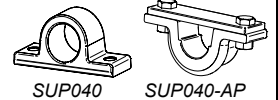

SUP040

SUP040-AP

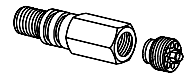

71720000 3/8 gas
71730000 1/2 gas

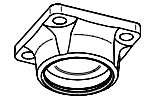

CH055-2957

PESO TOT. RIBALTABILE 10 Ton. a 180 Bar
ÖSSZTEHERBÍRÁS 10 TONNA 180 BAR MELLETT

TOTAL WEIGHT TIP-UP 10 Ton. 180 Bar
GESAMTGEWICHT KIPPANHÄNGER 10 Ton. 180 Bar

TIPO TÍPUS TYPE TYP	DISEGNO - DRAWING RAJZ - ZEICHNUNG	CORSA - STROKE LÖKET - HUB	Ø SFILATE mm Ø TAGOK mm Ø EXTENSIONS mm Ø STUFEN mm								DIMENSIONI CILINDRO MUNKAHENGER MÉRETEI CYLINDER DIMENSIONS ZYLINDER ABMESSUNGEN						L. sfilata - L. extension Tagok hossza - L. stufen	Peso - Kg - Weight		Volume oil Lt. Amount of oil Lt. Olajmennyiség - Liter Ölinhalt Lt.		
			46 TON. 2,9	61 TON. 5,2	76 TON. 8,1	91 TON. 11,7	107 TON. 16,1	126 TON. 22,4	145 TON. 29,7	165 TON. 38,4	187 TON. 49,4	C	C'	F	L	L'		R	F		S	
3041	3352	670	●	●	●	●							112	157	185	297	342	200	240	25	26,5	4
3042	3353	830	●	●	●	●							112	157	225	337	382	240	280	28,5	30	5
3043	3354	950	●	●	●	●							112	157	255	367	412	265	310	30	31,5	5,6
3044	3355	1050	●	●	●	●							112	157	280	392	437	290	335	32	33,5	6,2
3045	3356	1190	●	●	●	●							112	157	315	427	472	325	370	34,5	36	7
3046	3357	1290	●	●	●	●							112	157	340	452	497	350	395	37,5	39	7,5
3047	3358	1510	●	●	●	●							112	157	395	507	552	405	450	41,5	43	8,8
3048	3359	1710	●	●	●	●							112	157	445	557	602	450	500	45	46,5	10
3049	3360	1990	●	●	●	●							112	157	515	627	672	520	570	49,5	51	11

PRESSIONE MAX. DI ESERCIZIO 180 BAR - MAXIMÁLIS NYOMÁS 180 BAR
WORKING MAX. PRESSURE 180 BAR - MAX. BETRIEBSDRUCK 180 BAR

CILINDRI TELESCOPICI CON 4 SFILATE
TELESCOPIC CYLINDERS WITH 4 EXTENSIONS

TELESZKÓPOS MUNKAHENGER TAGÚ
TELESKOPZYLINDER MIT 4 VERLÄNGERUNGEN

TYPE F :
FORO
FURATOS
HOLE
LOCH

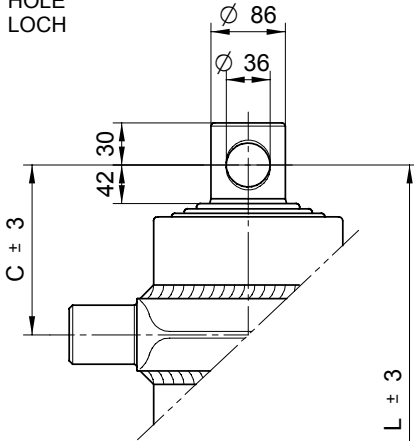

TYPE S :
SFERA
GÖMBÖS
BALL
KUGEL

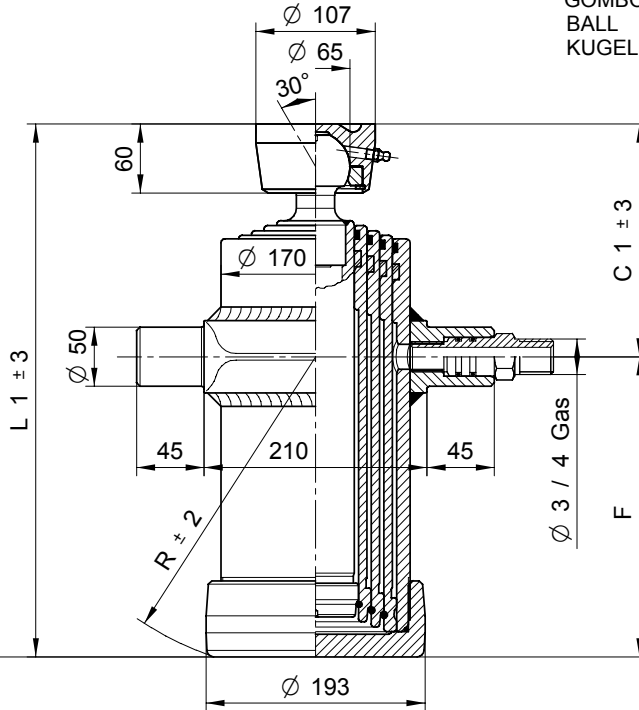

OPCIÓK

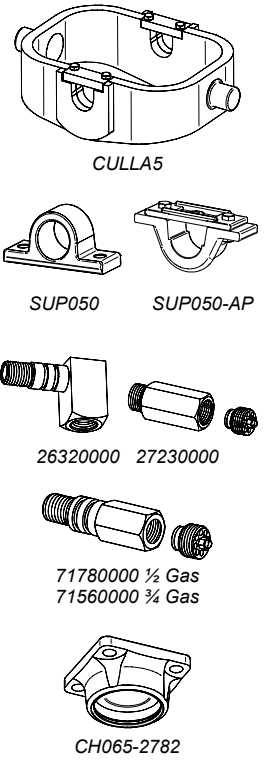

PESO TOT. RIBALTABILE 20 Ton. a 180 Bar

TOTAL WEIGHT TIP-UP 20 Ton. 180 Bar

ÖSSZTEHERBÍRÁS 20 TONNA 180 BAR MELLETT

GESAMTGEWICHT KIPPANHÄNGER 20 Ton. 180 Bar

TIPO TÍPUS TYPE	DISEGNO - DRAWING RAJZ - ZEICHNUNG	CORSA - STROKE LÖKET - HUB	Ø SFILATE mm Ø TAGOK mm Ø EXTENSIONS mm Ø STUFEN mm								DIMENSIONI CILINDRO MUNKAHENGER MÉRETEI CYLINDER DIMENSIONS ZYLINDER ABMESSUNGEN						L. sfilata - L. extension Tagok hossza - L. stufen	Peso - Kg - Weight Tömeg - Kg - Gewicht		Volume oil Lt. Amount of oil Lt. Olajmennyiség - Liter Ölínhalt Lt.			
			68 TON. 6,5	88 TON. 10,9	107 TON. 16,1	126 TON. 22,4	145 TON. 29,7	165 TON. 38,4	187 TON. 49,4	210 TON. 62,3	236 TON. 78,5	C	C'	F	L	L'		R	F		S		
4070	9805	1030	●	●	●	●							200	244	205	405	449	230	335	55	57	11,7	
4071	9807	970	●	●	●	●							200	244	190	390	434	215	320	50	52	11,5	
4072	9810	1210	●	●	●	●							200	244	250	450	494	270	380	60	62	13,7	
4045	3388	1490	●	●	●	●							200	244	320	520	564	335	450	67	69	16,8	
4046	3389	1690	●	●	●	●							200	244	370	570	614	385	500	74	76	19	
4047	3390	1970	●	●	●	●							200	244	440	640	684	450	570	82	84	22,2	
4090	13625	2510	●	●	●	●							200	244	600	800	844	610	730	100	102	30	

PRESSIONE MAX. DI ESERCIZIO 180 BAR - MAXIMÁLIS NYOMÁS 180 BAR
WORKING MAX. PRESSURE 180 BAR - MAX. BETRIEBSDRUCK 180 BAR

CILINDRI TELESCOPICI CON 4 SFILATE
TELESCOPIC CYLINDERS WITH 4 EXTENSIONS

TELESZKÓPOS MUNKAHENGER TAGÚ
TELESKOPZYLINDER MIT 4 VERLÄNGERUNGEN

TYPE F :
FORO
FURATOS
HOLE
LOCH

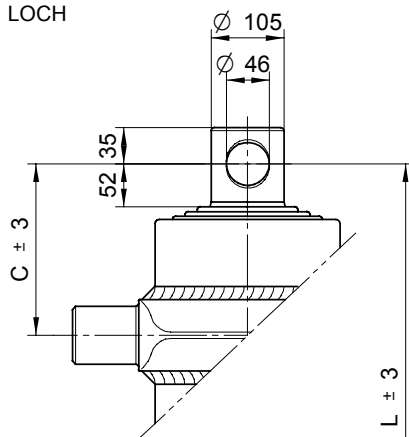

TYPE S :
SFERA
GÖMBÖS
BALL
KUGEL

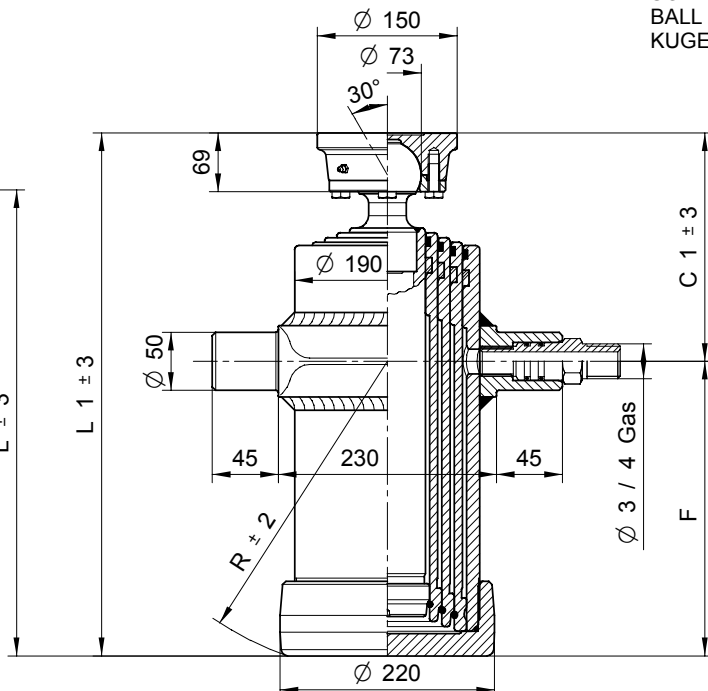

OPCIÓK

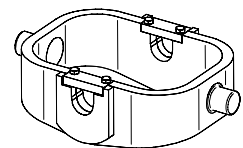

CULLA6

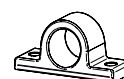

SUP050



SUP050-AP

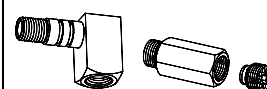

26320000 27230000

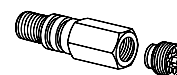

71780000 1/2 Gas
71560000 3/4 Gas

PESO TOT. RIBALTABILE 25 Ton. a 180 Bar

TOTAL WEIGHT TIP-UP 25 Ton. 180 Bar

ÖSSZTEHERBÍRÁS 25 TONNA 180 BAR MELLETT

GESAMTGEWICHT KIPPANHÄNGER 25 Ton. 180 Bar

TIPO TÍPUS TYPE TYP	DISEGNO - DRAWING RAJZ - ZEICHNUNG	CORSIA - STROKE LÖKET - HUB	Ø SFILATE mm Ø TAGOK mm Ø EXTENSIONS mm Ø STUFEN mm								DIMENSIONI CILINDRO MUNKAHENGER MÉRETEI CYLINDER DIMENSIONS ZYLINDER ABMESSUNGEN						L. sfilata - L. extension Tagok hossza - L. stufen	Peso - Kg - Weight Tömeg - Kg - Gewicht		Volume oil Lt. Amount of oil Lt. Olajmennyiség - Liter Ölínhalt Lt.		
			68 TON. 6,5	88 TON. 10,9	107 TON. 16,1	126 TON. 22,4	145 TON. 29,7	165 TON. 38,4	187 TON. 49,4	210 TON. 62,3	236 TON. 78,5	C	C'	F	L	L'		R	F		S	
4080	9815	1010		●	●	●	●					212	253	210	422	463	240	335	70	72	15,8	
4081	9820	1190		●	●	●	●					212	253	255	467	508	280	380	76	78	18,5	
4082	9825	1470		●	●	●	●					212	253	325	537	578	345	450	86	88	22,6	
4083	9830	1670		●	●	●	●					212	253	375	587	628	390	500	92	94	25,6	
4048	3391	1950		●	●	●	●					212	253	445	657	698	460	570	100	102	29,7	
4049	3392	2510		●	●	●	●					212	253	605	817	858	615	730	126	128	40	
4084	9832	2190		●	●	●	●					202	243	535	737	778	545	650	116	118	33	

PRESSIONE MAX. DI ESERCIZIO 180 BAR - MAXIMÁLIS NYOMÁS 180 BAR
WORKING MAX. PRESSURE 180 BAR - MAX. BETRIEBSDRUCK 180 BAR

CARATTERISTICHE TECNICHE DATE A TITOLO PURAMENTE INDICATIVO E MODIFICABILI SENZA PREAVVISO - THESE TECHNICAL SPECIFICATIONS ARE ONLY APPROXIMATE VALUES AND MAY BE CHANGED WITHOUT ANY PREVIOUS NOTICE
AZ ADATOK TÁJÉKOZTATÓ JELLEGŰEK, AZOKTÓL ELŐZETES FELHÍVÁS NÉLKÜL IS ELTÉRHETNEK - DIESE TECHNISHEN DATEN GELTEN NUR ALS RICHTWERTE UND KÖNNEN OHNE VORANMELDUNG GEÄNDERT WERDEN

CILINDRI TELESCOPICI CON 5 SFILATE
TELESCOPIC CYLINDERS WITH 5 EXTENSIONS

TELESZKÓPOS MUNKAHENGER TAGÚ
TELESKOPZYLINDER MIT 5 VERLÄNGERUNGEN

TYPE F :
FORO
FURATOS
HOLE
LOCH

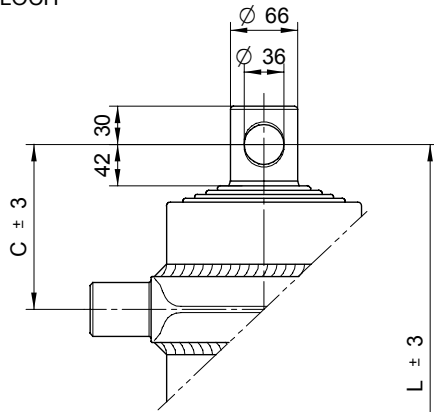

TYPE S :
SFERA
GÖMBÖS
BALL
KUGEL

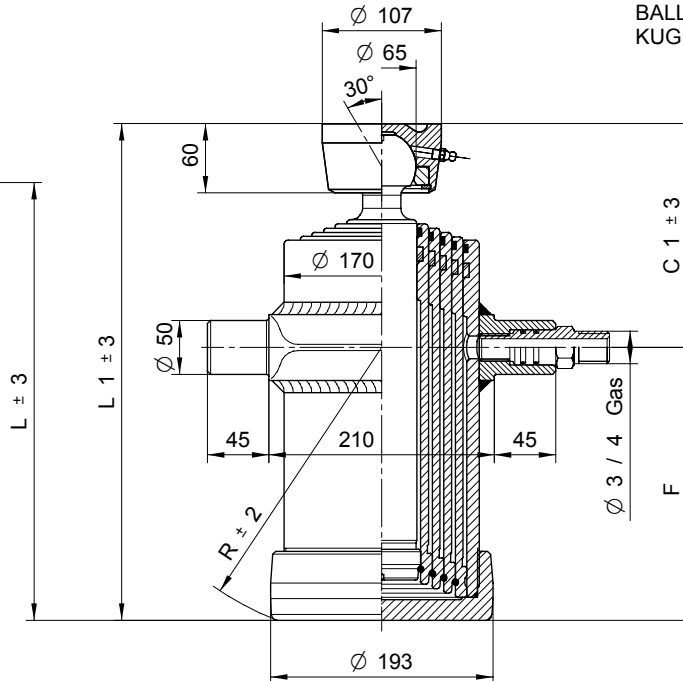

OPCIÓK

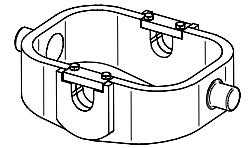

CULLA5

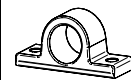

SUP050



SUP050-AP

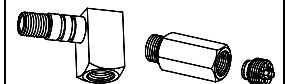

26320000 27230000

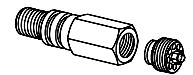

71780000 1/2 Gas
71560000 3/4 Gas

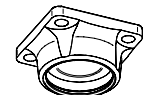

CH065-2782

ÖSSZTEHERBÍRÁS 16 TONNA 180 BAR MELLETT
POIDS TOT. REBATABLE 16 Ton. au 180 Bar

TOTAL WEIGHT TIP-UP 16 Ton. 180 Bar
GESAMTGEWICHT KIPPANHÄNGER 16 Ton. 180 Bar

TIPO TÍPUS TYPE TYPE	DISEGNO - DRAWING RAJZ - ZEICHNUNG	CORSIA - STROKE LÖKET - HUB	Ø SFILATE mm Ø TAGOK mm Ø EXTENSIONS mm Ø STUFEN mm										DIMENSIONI CILINDRO MUNKAHENGER MÉRETEI CYLINDER DIMENSIONS ZYLINDER ABMESSUNGEN						L. sfilata - L. extension Tagok hossza - L. stufen	Peso - Kg - Weight Tömeg - Kg - Gewicht		Volume oil Lt. Amount of oil Lt. Olajmennyiség - Liter Ölínhalt Lt.	
			68 TON. 6,5	88 TON. 10,9	107 TON. 16,1	126 TON. 22,4	145 TON. 29,7	165 TON. 38,4	187 TON. 49,4	210 TON. 62,3	236 TON. 78,5	C	C'	F	L	L'	R	F		S			
5000	9835	1295	●	●	●	●	●						205	245	205	410	450	230	335	63	65,5	12,7	
5001	9840	1520	●	●	●	●	●						205	245	250	455	495	270	380	70	72,5	14,8	
4050	3393	1870	●	●	●	●	●						205	245	320	525	565	335	450	79	81,5	18,2	
4051	3394	2120	●	●	●	●	●						205	245	370	575	615	385	500	86	88,5	20,6	
5002	9755	2470	●	●	●	●	●						205	245	440	645	685	450	570	95	97,5	24	
5015	14445	2990	●	●	●	●	●						205	245	570	775	815	580	700	114	116,5	29	

PRESSIONE MAX. DI ESERCIZIO 180 BAR - MAXIMÁLIS NYOMÁS 180 BAR
WORKING MAX. PRESSURE 180 BAR - MAX. BETRIEBSDRUCK 180 BAR

CILINDRI TELESCOPICI CON 5 SFILATE
TELESCOPIC CYLINDERS WITH 5 EXTENSIONS

TELESZKÓPOS MUNKAHENGER TAGÚ
TELESKOPZYLINDER MIT 5 VERLÄNGERUNGEN

TYPE F :
FORO
FURATOS
HOLE
LOCH

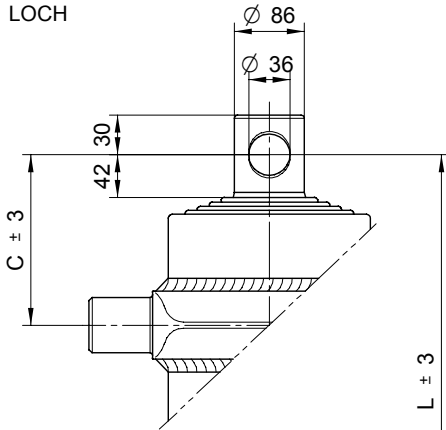

TYPE S :
SFERA
GÖMBÖS
BALL
KUGEL

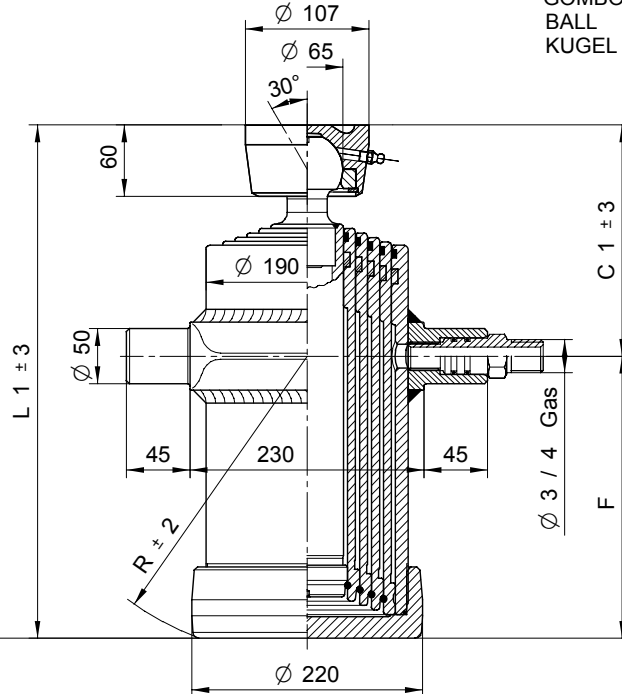

OPCIÓK

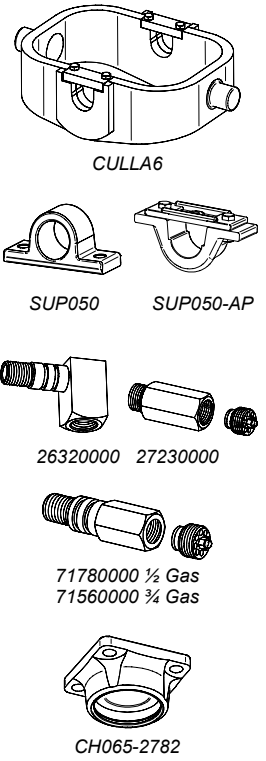

PESO TOT. RIBALTABILE 22 Ton. a 180 Bar

TOTAL WEIGHT TIP-UP 22 Ton. 180 Bar

ÖSSZTEHERBÍRÁS 22 TONNA 180 BAR MELLETT

GESAMTGEWICHT KIPPANHÄNGER 22 Ton. 180 Bar

TIPO TÍPUS TYPE TYP	DISEGNO - DRAWING RAJZ - ZEICHNUNG	CORSA - STROKE LÖKET - HUB	Ø SFILATE mm Ø TAGOK mm Ø EXTENSIONS mm Ø STUFEN mm										DIMENSIONI CILINDRO MUNKAHENGER MÉRETEI CYLINDER DIMENSIONS ZYLINDER ABMESSUNGEN						L. sfilata - L. extension Tagok hossza - L. stufen	Peso - Kg - Weight Tömeg - Kg - Gewicht		Volume oil Lt. Amount of oil Lt. Olajmennyiség - Liter Olinhalt Lt.	
			68 TON. 6,5	88 TON. 10,9	107 TON. 16,1	126 TON. 22,4	145 TON. 29,7	165 TON. 38,4	187 TON. 49,4	210 TON. 62,3	236 TON. 78,5	C	C'	F	L	L'	R	F		S			
5005	9845	1275	●	●	●	●	●						205	245	205	410	450	235	335	70	72,5	17,5	
5006	9850	1500	●	●	●	●	●						205	245	250	455	495	275	380	77	79,5	20,3	
5007	9855	1850	●	●	●	●	●						205	245	320	525	565	340	450	86	88,5	25	
4052	3395	2100	●	●	●	●	●						205	245	370	575	615	390	500	92	94,5	28,2	
4053	3396	2450	●	●	●	●	●						205	245	440	655	695	460	570	101	103,5	32,8	
5010	9954	3490	●	●	●	●	●						205	245	670	875	915	680	800	131	133,5	46	
5011	9955	2990	●	●	●	●	●						205	245	570	775	815	580	700	118	120,5	40	

PRESSIONE MAX. DI ESERCIZIO 180 BAR - MAXIMÁLIS NYOMÁS 180 BAR
WORKING MAX. PRESSURE 180 BAR - MAX. BETRIEBSDRUCK 180 BAR

CILINDRI TELESCOPICI CON 6 SFILATE
TELESCOPIC CYLINDERS WITH 6 EXTENSIONS

TELESZKÓPOS MUNKAHENGER 6 TAGÚ
TELESKOPZYLINDER MIT 6 VERLÄNGERUNGEN

TYPE F :
FORO
FURATOS
HOLE
LOCH

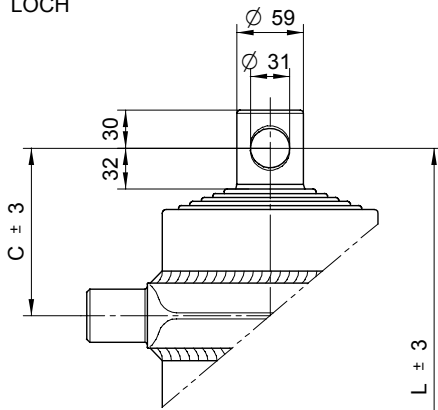

TYPE S :
SFERA
GÖMBÖS
BALL
KUGEL

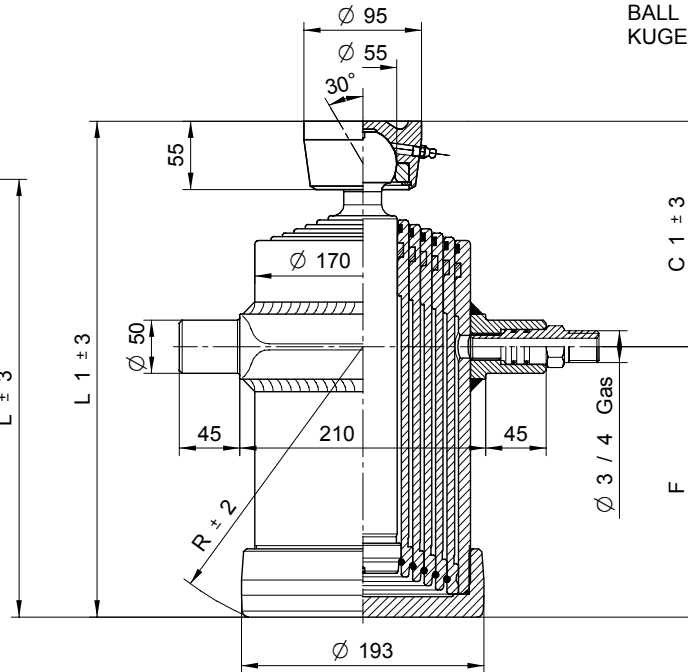

OPCIÓK

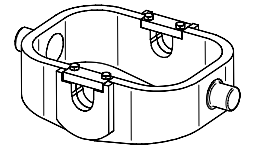

CULLA5

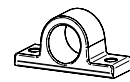

SUP050

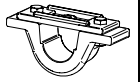

SUP050-AP

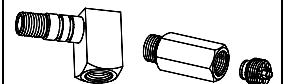

26320000 27230000

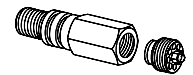

71780000 1/2 Gas
71560000 3/4 Gas

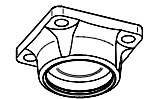

CH055-2957

PESO TOT. RIBALTABILE 13 Ton. a 180 Bar

TOTAL WEIGHT TIP-UP 13 Ton. 180 Bar

ÖSSZTEHERBÍRÁS 13 TONNA 180 BAR MELLETT

GESAMTGEWICHT KIPPANHÄNGER 13 Ton. 180 Bar

TIPO TÍPUS TYPE	DISEGNO - DRAWING RAJZ - ZEICHNUNG	CORSA - STROKE LÖKET - HUB	Ø SFILATE mm Ø TAGOK mm Ø EXTENSIONS mm Ø STUFEN mm								DIMENSIONI CILINDRO MUNKAHENGER MÉRETEI CYLINDER DIMENSIONS ZYLINDER ABMESSUNGEN						L. sfilata - L. extension Tagok hossza - L. stufen	Peso - Kg - Weight		Volume oil Lt. Amount of oil Lt. Olajmennyiség - Liter Ölinhalt Lt.		
			30 TON. 1,1	46 TON. 2,9	61 TON. 5,2	76 TON. 8,1	91 TON. 11,7	107 TON. 16,1	126 TON. 22,4	145 TON. 29,7	165 TON. 38,4	C	C'	F	L	L'		R	F		S	
6017	14340	987			●	●	●	●	●	●			195	240	110	305	350	150	240	48	50	10
6018	11815	1165			●	●	●	●	●	●			195	240	140	335	380	170	270	52	54	10,5
6019	11816	1345			●	●	●	●	●	●			195	240	170	365	410	197	300	57	59	12
6020	9800	1470			●	●	●	●	●	●			195	240	190	385	430	215	320	59	61	13
6021	11817	1765			●	●	●	●	●	●			195	240	240	435	480	260	370	66	68	15,6
6022	11818	2245			●	●	●	●	●	●			195	240	320	515	560	335	450	76	78	19,8
6023	11819	2545			●	●	●	●	●	●			195	240	370	565	610	385	500	84	86	23
6024	11830	2965			●	●	●	●	●	●			195	240	440	635	680	450	570	93	95	26
6025	11835	3585			●	●	●	●	●	●			195	240	570	765	810	580	700	112	114	32

PRESSIONE MAX. DI ESERCIZIO 180 BAR - MAXIMÁLIS NYOMÁS 180 BAR
WORKING MAX. PRESSURE 180 BAR - MAX. BETRIEBSDRUCK 180 BAR

CILINDRI TELESCOPICI CON 6 SFILATE
TELESCOPIC CYLINDERS WITH 6 EXTENSIONS

TELESZKÓPOS MUNKAHENGER 6 TAGÚ
TELESKOPZYLINDER MIT 6 VERLÄNGERUNGEN

TYPE F :
FORO
FURATOS
HOLE
LOCH

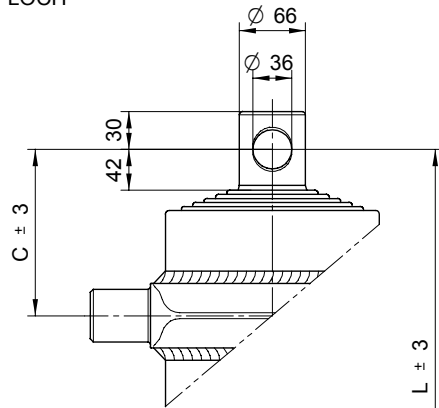

TYPE S :
SFERA
GÖMBÖS
BALL
KUGEL

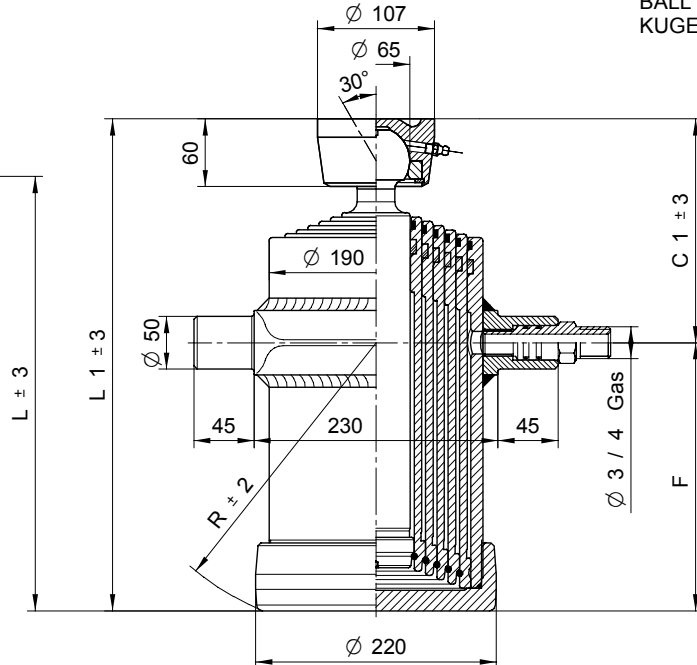

OPCIÓK

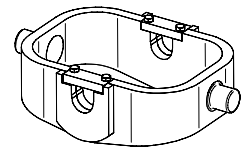

CULLA6

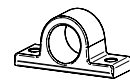

SUP050

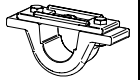

SUP050-AP

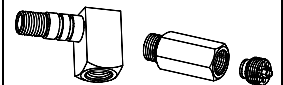

26320000 27230000

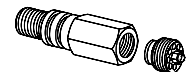

71780000 1/2 Gas
71560000 3/4 Gas

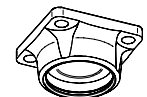

CH065-2782

PESO TOT. RIBALTABILE 20 Ton. a 180 Bar

TOTAL WEIGHT TIP-UP 20 Ton. 180 Bar

ÖSSZTEHERBÍRÁS 20 TONNA 180 BAR MELLETT

GESAMTGEWICHT KIPPANHÄNGER 20 Ton. 180 Bar

TIPO TÍPUS TYPE TYP	DISEGNO - DRAWING RAJZ - ZEICHNUNG	CORSA - STROKE LÖKET - HUB	Ø SFILATE mm Ø TAGOK mm Ø EXTENSIONS mm Ø STUFEN mm								DIMENSIONI CILINDRO MUNKAHENGER MÉRETEI CYLINDER DIMENSIONS ZYLINDER ABMESSUNGEN						L. sfilata - L. extension Tagok hossza - L. stufen	Peso - Kg - Weight		Volume olio Lt. Amount of oil Lt. Olajmennyiség - Liter Ölínhalt Lt.								
			68 TON. 6,5	88 TON. 10,9	107 TON. 16,1	126 TON. 22,4	145 TON. 29,7	165 TON. 38,4	187 TON. 49,4	210 TON. 62,3	236 TON. 78,5	C	C'	F	L	L'		R	F		S							
4058	3397	1540	●	●	●	●	●	●											208	248	210	418	458	235	335	80	82	18,5
4059	3387	1810	●	●	●	●	●	●											208	248	255	463	503	275	380	87	89	21,5
4060	4281	2225	●	●	●	●	●	●											208	248	325	533	573	345	450	100	102	25,9
4061	4282	2525	●	●	●	●	●	●											208	248	375	583	623	390	500	108	110	29,4
4062	4283	2950	●	●	●	●	●	●											208	248	445	653	693	460	570	123	125	34,6
4063	4284	3405	●	●	●	●	●	●											208	248	545	753	793	555	670	142	144	40
4064	4280	3585	●	●	●	●	●	●											208	248	575	783	823	585	700	147	149	42
4065	5305	3765	●	●	●	●	●	●											208	248	605	813	853	615	730	153	155	44
4066	14505	4185	●	●	●	●	●	●											208	248	675	883	923	685	800	172	174	49

PRESSIONE MAX. DI ESERCIZIO 180 BAR - MAXIMÁLIS NYOMÁS 180 BAR
WORKING MAX. PRESSURE 180 BAR - MAX. BETRIEBSDRUCK 180 BAR

CILINDRI TELESCOPICI CON 6 SFILATE
TELESCOPIC CYLINDERS WITH 6 EXTENSIONS

TELESZKÓPOS MUNKAHENGER 6 TAGÚ
TELESKOPZYLINDER MIT 6 VERLÄNGERUNGEN

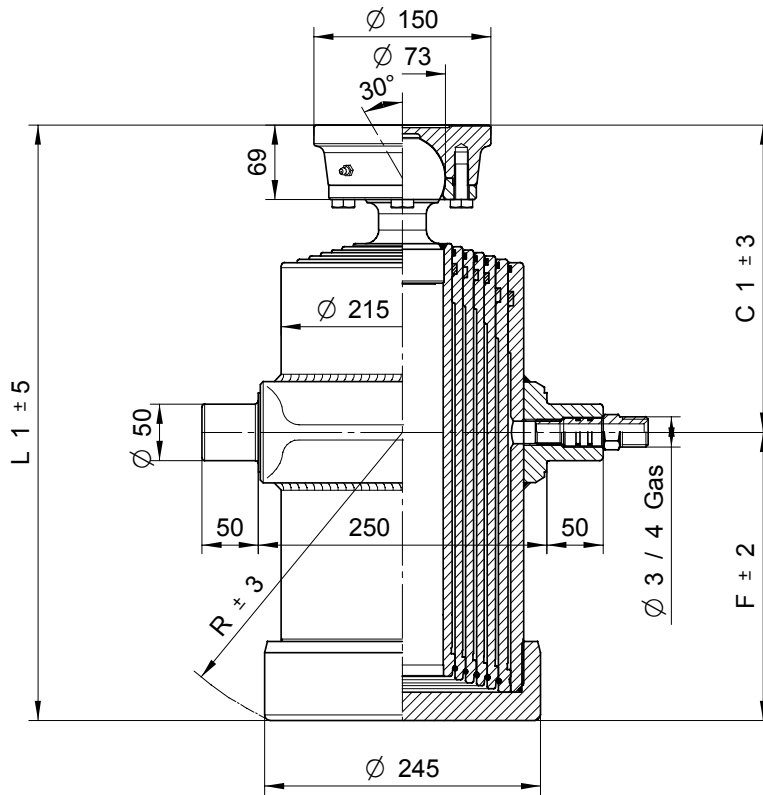

TYPE S :
SFERA
GÖMBÖS
BALL
KUGEL

OPCIÓK

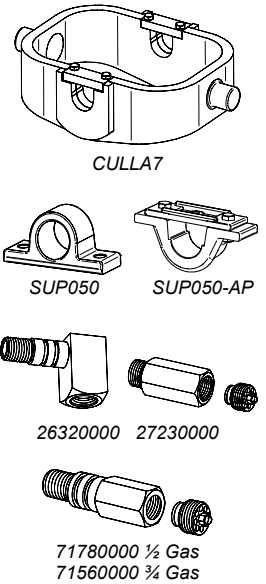

PESO TOT. RIBALTABILE 25 Ton. a 180 Bar
ÖSSZTEHERBÍRÁS 25 TONNA 180 BAR MELLETT

TOTAL WEIGHT TIP-UP 25 Ton. 180 Bar
GESAMTGEWICHT KIPPANHÄNGER 25 Ton. 180 Bar

TIPO TÍPUS TYPE TYP	DISEGNO - DRAWING RAJZ - ZEICHNUNG	CORSA - STROKE LÖKET - HUB	Ø SFILATE mm Ø TAGOK mm Ø EXTENSIONS mm Ø STUFEN mm								DIMENSIONI CILINDRO MUNKAHENGER MÉRETEI CYLINDER DIMENSIONS ZYLINDER ABMESSUNGEN						L. sfilata - L. extension Tagok hossza - L. stufen	Peso - Kg - Weight Tömeg - Kg - Gewicht		Volume oil Lt. Amount of oil Lt. Olajmennyiség - Liter Ölínhalt Lt.	
			68 TON. 6,5	88 TON. 10,9	107 TON. 16,1	126 TON. 22,4	145 TON. 29,7	165 TON. 38,4	187 TON. 49,4	210 TON. 62,3	236 TON. 78,5	C	C'	F	L	L'		R	F		S
6050	14040	1415		●	●	●	●	●	●			-	260	195	-	455	230	320	-	99	22
6051	14041	1505		●	●	●	●	●	●			-	260	210	-	470	244	335	-	101	23
6052	14042	1755		●	●	●	●	●	●			-	260	255	-	515	283	380	-	110	28
6053	14043	2175		●	●	●	●	●	●			-	260	325	-	585	348	450	-	125	34
6054	14044	2475		●	●	●	●	●	●			-	260	375	-	635	395	500	-	134	38
6055	14045	2895		●	●	●	●	●	●			-	260	445	-	705	462	570	-	148	45
6056	14046	3265		●	●	●	●	●	●			-	260	525	-	785	535	650	-	165	51
6057	13910	3565		●	●	●	●	●	●			-	260	575	-	835	590	700	-	171	56

PRESSIONE MAX. DI ESERCIZIO 180 BAR - MAXIMÁLIS NYOMÁS 180 BAR
WORKING MAX. PRESSURE 180 BAR - MAX. BETRIEBSDRUCK 180 BAR

CILINDRI TELESCOPICI CON 6 SFILATE
TELESCOPIC CYLINDERS WITH 6 EXTENSIONS

TELESZKÓPOS MUNKAHENGER 6 TAGÚ
TELESKOPZYLINDER MIT 6 VERLÄNGERUNGEN

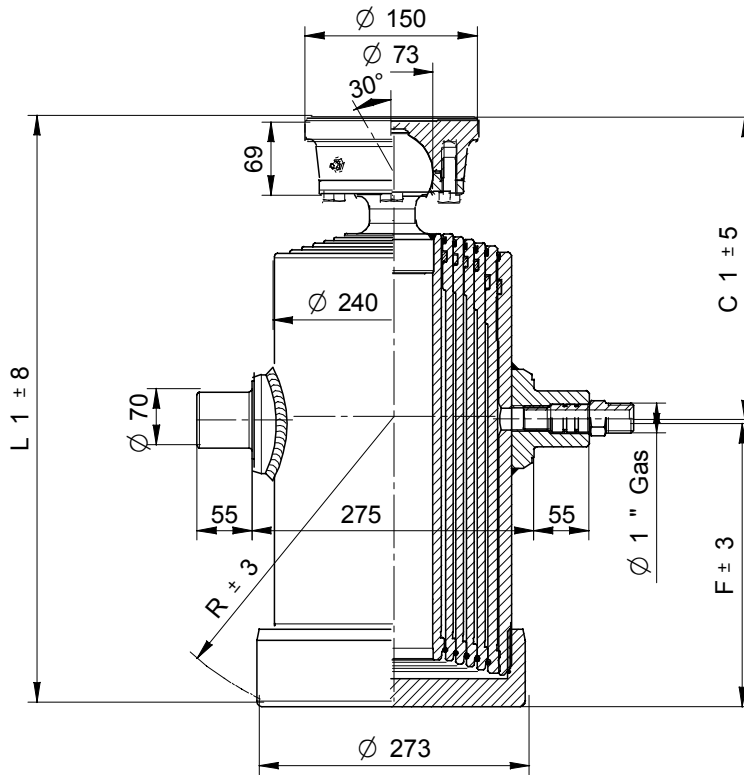

TYPE S :
SFERA
GOMBÓS
BALL
KUGEL

OPCIÓK

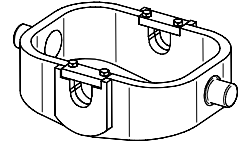

CULLA8A

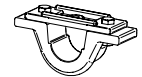

SUP070-AP

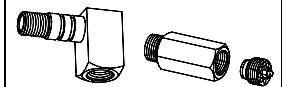

26790000 27240000

PESO TOT. RIBALTABILE 32 Ton. a 180 Bar
ÖSSZTEHERBÍRÁS 32 TONNA 180 BAR MELLETT

TOTAL WEIGHT TIP-UP 32 Ton. 180 Bar
GESAMTGEWICHT KIPPANHÄNGER 32 Ton. 180 Bar

TIPO TÍPUS TYPE TYP	DISEGNO - DRAWING RAJZ - ZEICHNUNG	CORSO - STROKE LÖKET - HUB	Ø SFILATE mm Ø TAGOK mm Ø EXTENSIONS mm Ø STUFEN mm							DIMENSIONI CILINDRO MUNKAHENGER MÉRETEI CYLINDER DIMENSIONS ZYLINDER ABMESSUNGEN						L.sfilata - L. extension Tagok hossza - L. stufen	Peso - Kg - Weight		Volume olio Lt. Amount of oil Lt. Olajmennyiség - Liter Ölminhalt Lt.	
			88 TON. 10,9	107 TON. 16,1	126 TON. 22,4	145 TON. 29,7	165 TON. 38,4	187 TON. 49,4	210 TON. 62,3	236 TON. 78,5	265 TON. 99,2	C	C ¹	F	L		L ¹	R		F
6059	12640	1260	●	●	●	●	●	●			-	235	205	-	440	248	300	-	108	25
6060	12641	1380	●	●	●	●	●	●			-	235	225	-	460	265	320	-	115	27,5
6061	12642	1470	●	●	●	●	●	●			-	235	240	-	475	277	335	-	119	29,5
6062	12643	1680	●	●	●	●	●	●			-	255	265	-	520	300	380	-	129	33
6063	12644	1920	●	●	●	●	●	●			-	255	305	-	560	335	420	-	140	37,2
6064	12645	2100	●	●	●	●	●	●			-	255	335	-	590	364	450	-	146	40,5
6065	12646	2400	●	●	●	●	●	●			-	255	385	-	640	410	500	-	158	47,5
6066	12647	2640	●	●	●	●	●	●			-	255	425	-	680	448	540	-	173	52,5
6067	12648	2820	●	●	●	●	●	●			-	255	455	-	710	478	570	-	186	56
6068	12649	3220	●	●	●	●	●	●			-	255	535	-	790	552	650	-	212	64,5
6069	12654	3520	●	●	●	●	●	●			-	255	585	-	840	600	700	-	235	70,5

PRESSIONE MAX. DI ESERCIZIO 180 BAR - MAXIMÁLIS NYOMÁS 180 BAR
WORKING MAX. PRESSURE 180 BAR - MAX. BETRIEBSDRUCK 180 BAR

CILINDRI TELESCOPICI CON 6 SFILATE
TELESCOPIC CYLINDERS WITH 6 EXTENSIONS

TELESZKÓPOS MUNKAHENGER 6 TAGÚ
TELESKOPZYLINDER MIT 6 VERLÄNGERUNGEN

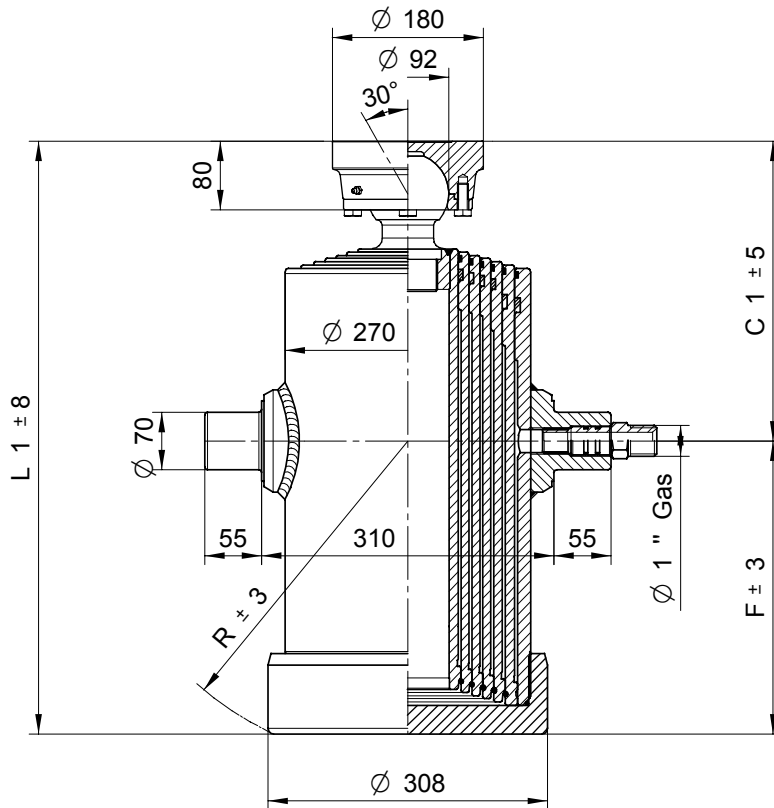

TYPE S :
SFERA
GÖMBÖS
BALL
KUGEL

OPCIÓK

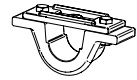

SUP070-AP

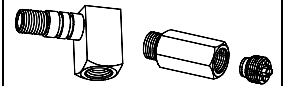

26790000 27240000

PESO TOT. RIBALTABILE 40 Ton. a 180 Bar

TOTAL WEIGHT TIP-UP 40 Ton. 180 Bar

ÖSSZTEHERBÍRÁS 40 TONNA 180 BAR MELLETT

GESAMTGEWICHT KIPPANHÄNGER 40 Ton. 180 Bar

TIPO TÍPUS TYPE TYP	DISEGNO - DRAWING RAJZ - ZEICHNUNG	CORSA - STROKE LÖKET - HUB	Ø SFILATE mm Ø TAGOK mm Ø EXTENSIONS mm Ø STUFEN mm								DIMENSIONI CILINDRO MUNKAHENGER MÉRETEI CYLINDER DIMENSIONS ZYLINDER ABMESSUNGEN						L. sfilata - L. extension Tagok hossza - L. stufen	Peso - Kg - Weight Tömeg - Kg - Gewicht	Volume oil Lt. Amount of oil Lt. Olajmennyiség - Liter Olímhalt Lt.			
			88 TON. 10,9	107 TON. 16,1	126 TON. 22,4	145 TON. 29,7	165 TON. 38,4	187 TON. 49,4	210 TON. 62,3	236 TON. 78,5	265 TON. 99,2	C	C'	F	L	L'				R	F	S
6029	14749	1215			●	●	●	●	●	●			-	250	209	-	459	260	300	-	147	30,8
6030	14750	1335			●	●	●	●	●	●			-	250	229	-	479	277	320	-	153	33,9
6031	14751	1425			●	●	●	●	●	●			-	250	244	-	494	289	335	-	158	36,3
6032	14752	1605			●	●	●	●	●	●			-	270	269	-	539	310	380	-	173	40
6033	14753	1845			●	●	●	●	●	●			-	270	309	-	579	346	420	-	187	46,3
6034	14754	2025			●	●	●	●	●	●			-	270	339	-	609	373	450	-	202	51
6035	14755	2325			●	●	●	●	●	●			-	270	389	-	659	419	500	-	226	58,8
6036	14756	2565			●	●	●	●	●	●			-	270	429	-	699	456	540	-	246	65
6037	14757	2745			●	●	●	●	●	●			-	270	459	-	729	484	570	-	262	69,8

PRESSIONE MAX. DI ESERCIZIO 180 BAR - MAXIMÁLIS NYOMÁS 180 BAR
WORKING MAX. PRESSURE 180 BAR - MAX. BETRIEBSDRUCK 180 BAR

CILINDRI TELESCOPICI CON 6 SFILATE
TELESCOPIC CYLINDERS WITH 6 EXTENSIONS

TELESZKÓPOS MUNKAHENGER 6 TAGÚ
TELESKOPZYLINDER MIT 6 VERLÄNGERUNGEN

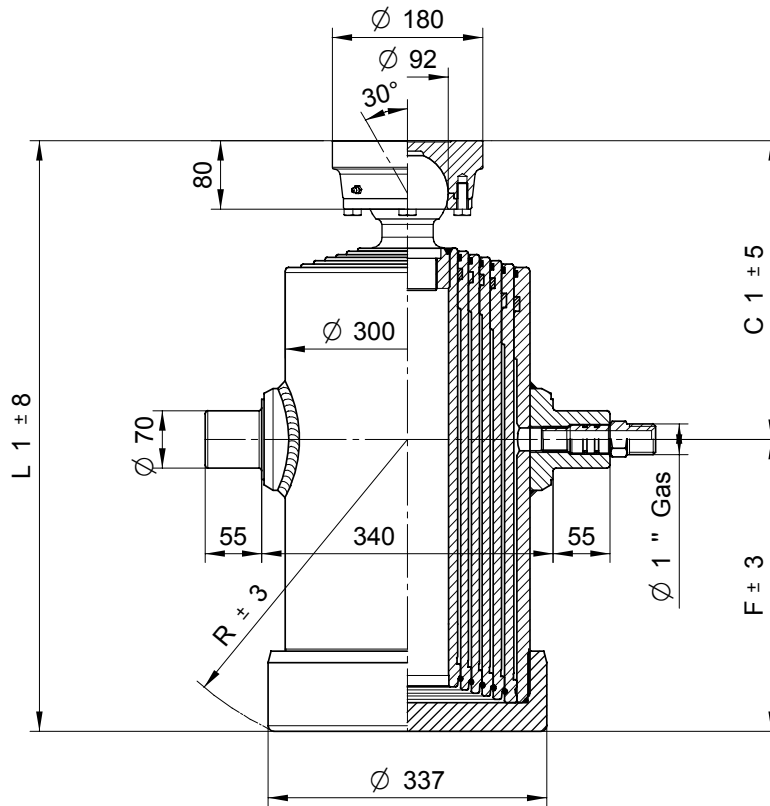

TYPE S :
SFERA
GÖMBÖS
BALL
KUGEL

OPCIÓK

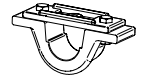

SUP070-AP

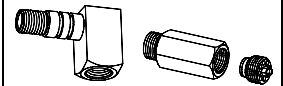

26790000 27240000

PESO TOT. RIBALTABILE 50 Ton. a 180 Bar

TOTAL WEIGHT TIP-UP 50 Ton. 180 Bar

ÖSSZTEHERBÍRÁS 50 TONNA 180 BAR MELLETT

GESAMTGEWICHT KIPPANHÄNGER 50 Ton. 180 Bar

TIPO TÍPUS TYPE TYP	DISEGNO - DRAWING RAJZ - ZEICHNUNG	CORSO - STROKE LÖKET - HUB	Ø SFILATE mm Ø TAGOK mm Ø EXTENSIONS mm Ø STUFEN mm								DIMENSIONI CILINDRO MUNKAHENGER MÉRETEI CYLINDER DIMENSIONS ZYLINDER ABMESSUNGEN						L. sfilata - L. extension Tagok hossza - L. stufen	Peso - Kg - Weight		Volume olio Lt. Amount of oil Lt. Olajmennyiség - Liter Ölinhalt Lt.	
			88 TON. 10,9	107 TON. 16,1	126 TON. 22,4	145 TON. 29,7	165 TON. 38,4	187 TON. 49,4	210 TON. 62,3	236 TON. 78,5	265 TON. 99,2	C	C'	F	L	L'		R	F		S
6079	14769	1170				●	●	●	●	●	●	-	250	212	-	462	272	300	-	182	37,7
6080	14770	1290				●	●	●	●	●	●	-	250	232	-	482	288	320	-	189	41,6
6081	14771	1380				●	●	●	●	●	●	-	250	247	-	497	300	335	-	194	44,6
6082	14772	1540				●	●	●	●	●	●	-	270	272	-	542	338	380	-	214	49,2
6083	14773	1780				●	●	●	●	●	●	-	270	312	-	582	373	420	-	230	57,2
6084	14774	1960				●	●	●	●	●	●	-	270	342	-	612	400	450	-	246	63,1
6085	14775	2260				●	●	●	●	●	●	-	270	392	-	662	446	500	-	266	73,1
6086	14776	2500				●	●	●	●	●	●	-	270	432	-	702	483	540	-	280	81
6087	14777	2680				●	●	●	●	●	●	-	270	462	-	732	511	570	-	296	87

PRESSIONE MAX. DI ESERCIZIO 180 BAR - MAXIMÁLIS NYOMÁS 180 BAR
WORKING MAX. PRESSURE 180 BAR - MAX. BETRIEBSDRUCK 180 BAR

CILINDRI TELESCOPICI CON 7 SFILATE

TELESCOPIC CYLINDERS WITH 7 EXTENSIONS

TELESKOPZYLINDER MIT 7 VERLÄNGERUNGEN

TYPE S :
 SFERA
 GÖMBÖS
 BALL
 KUGEL

OPCIÓK

CULLA5

SUP050 SUP050-AP

27230000

CH045-2414

PESO TOT. RIBALTABILE 10 Ton. a 180 Bar

TOTAL WEIGHT TIP-UP 10 Ton. 180 Bar

ÖSSZTEHERBÍRÁS 10 TONNA 180BAR MELLETT

GESAMTGEWICHT KIPPANHÄNGER 10 Ton. 180 Bar

TIPO TÍPUS TYPE TYP	DISEGNO - DRAWING RAJZ - ZEICHNUNG	CORSA - STROKE LÖKET - HUB	Ø SFILATE mm Ø TAGOK mm Ø EXTENSIONS mm Ø STUFEN mm								DIMENSIONI CILINDRO MUNKAHENGER MÉRETEI CYLINDER DIMENSIONS ZYLINDER ABMESSUNGEN						L.sfilata - L. extension Tagok hossza - L.stufen	Peso - Kg - Weight Tömeg - Kg - Gewicht		Volume oil Lt. Amount of oil Lt. Olajmennyiség - Liter Ölinhalt Lt.			
			30 TON. 1,1	46 TON. 2,9	61 TON. 5,2	76 TON. 8,1	91 TON. 11,7	107 TON. 16,1	126 TON. 22,4	145 TON. 29,7	165 TON. 38,4	C	C'	F	L	L'		R	F		S		
			7000	14235	890		●	●	●	●	●	●	●		-	165		115	-		280	150	200

PRESSIONE MAX. DI ESERCIZIO 180 BAR - MAXIMÁLIS NYOMÁS 180 BAR
WORKING MAX. PRESSURE 180 BAR - MAX. BETRIEBSDRUCK 180 BAR

CARATTERISTICHE TECNICHE DATE A TITOLO PURAMENTE INDICATIVO E MODIFICABILI SENZA PREAVVISO - THESE TECHNICAL SPECIFICATIONS ARE ONLY APPROXIMATE VALUES AND MAY BE CHANGED WITHOUT ANY PREVIOUS NOTICE
 AZ ADATOK TÁJÉKOZTATÓ JELLEGŰEK, AZOKTÓL ELŐZETES FELHÍVÁS NÉLKÜL IS ELTÉRHETNEK - DIESE TECHNISHEN DATEN GELTEN NUR ALS RICHTWERTE UND KÖNNEN OHNE VORANMELDUNG GEÄNDERT WERDEN

CILINDRI TELESCOPICI CON 7 SFILATE
TELESCOPIC CYLINDERS WITH 7 EXTENSIONS

TELESZKÓPOS MUNKAHENGER 7 TAGÚ
TELESKOPZYLINDER MIT 7 VERLÄNGERUNGEN

TYPE F :
FORO
FURATOS
HOLE
LOCH

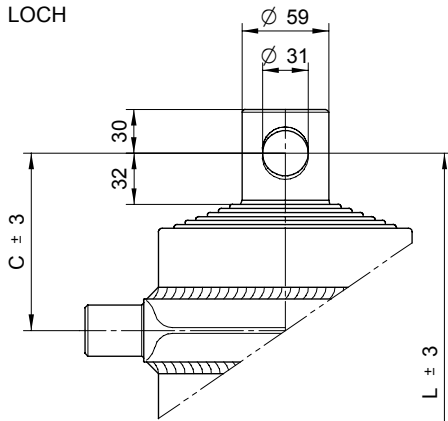

TYPE S :
SFERA
GÖMBÖS
BALL
KUGEL

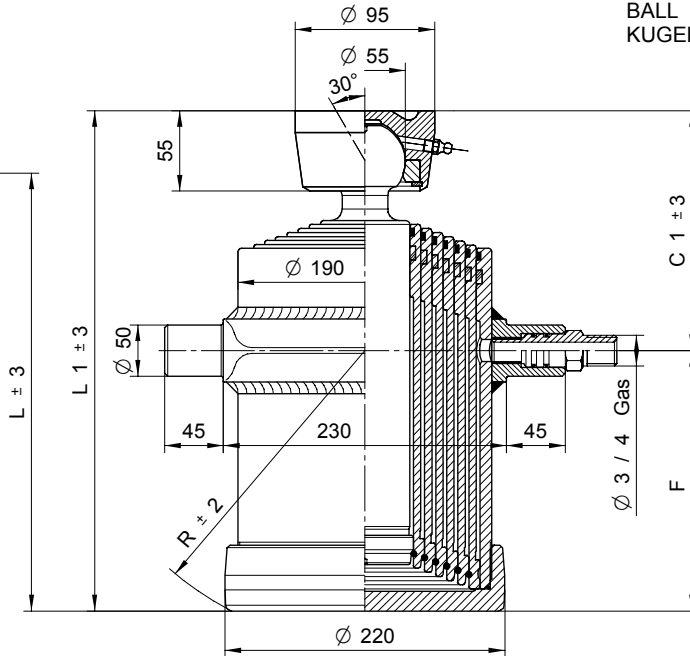

OPCIÓK

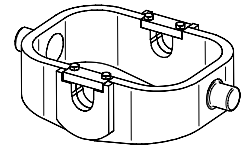

CULLA6

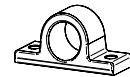

SUP050

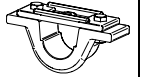

SUP050-AP

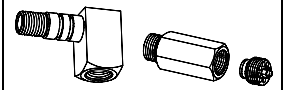

26320000 27230000

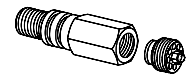

71780000 1/2 Gas
71560000 3/4 Gas

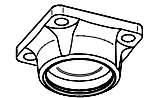

CH055-2957

PESO TOT. RIBALTABILE 14 Ton. a 180 Bar

TOTAL WEIGHT TIP-UP 14 Ton. 180 Bar

ÖSSZTEHERBÍRÁS 14 TONNA 180BAR MELLETT

GESAMTGEWICHT KIPPANHÄNGER 14 Ton. 180 Bar

TIPO TÍPUS TYPE	DISEGNO - DRAWING RAJZ - ZEICHNUNG	CORSA - STROKE LÖKET - HUB	Ø SFILATE mm Ø TAGOK mm Ø EXTENSIONS mm Ø STUFEN mm								DIMENSIONI CILINDRO MUNKAHENGER MÉRETEI CYLINDER DIMENSIONS ZYLINDER ABMESSUNGEN						L. sfilata - L. extension Tagok hossza - L. stufen	Peso - Kg - Weight		Volume oil Lt. Amount of oil Lt. Olajmennyiség - Liter Ölinhalt Lt.	
			30 TON. 1,1	46 TON. 2,9	61 TON. 5,2	76 TON. 8,1	91 TON. 11,7	107 TON. 16,1	126 TON. 22,4	145 TON. 29,7	165 TON. 38,4	C	C'	F	L	L'		R	F		S
7015	12810	1135			●	●	●	●	●	●	●	198	243	115	313	358	160	240	56,5	58,5	13
7016	12811	1345			●	●	●	●	●	●	●	198	243	145	343	388	182	270	62	64	15
7017	12812	1695			●	●	●	●	●	●	●	198	243	195	393	438	225	320	71,5	73,5	19
7018	12813	1800			●	●	●	●	●	●	●	198	243	210	408	453	238	335	74,5	76,5	20
7019	12814	2045			●	●	●	●	●	●	●	198	243	245	443	488	270	370	81	83	22
7020	12815	2600			●	●	●	●	●	●	●	198	243	325	523	568	345	450	95,5	97,5	28
7021	12816	2950			●	●	●	●	●	●	●	198	243	375	573	618	390	500	105	107	32
7022	11145	3445			●	●	●	●	●	●	●	198	243	445	643	688	458	570	118	120	38

PRESSIONE MAX. DI ESERCIZIO 180 BAR - MAXIMÁLIS NYOMÁS 180 BAR
WORKING MAX. PRESSURE 180 BAR - MAX. BETRIEBSDRUCK 180 BAR

CILINDRI TELESCOPICI CON 7 SFILATE
TELESCOPIC CYLINDERS WITH 7 EXTENSIONS

TELESZKÓPOS MUNKAHENGER 7 TAGÚ
TELESKOPZYLINDER MIT 7 VERLÄNGERUNGEN

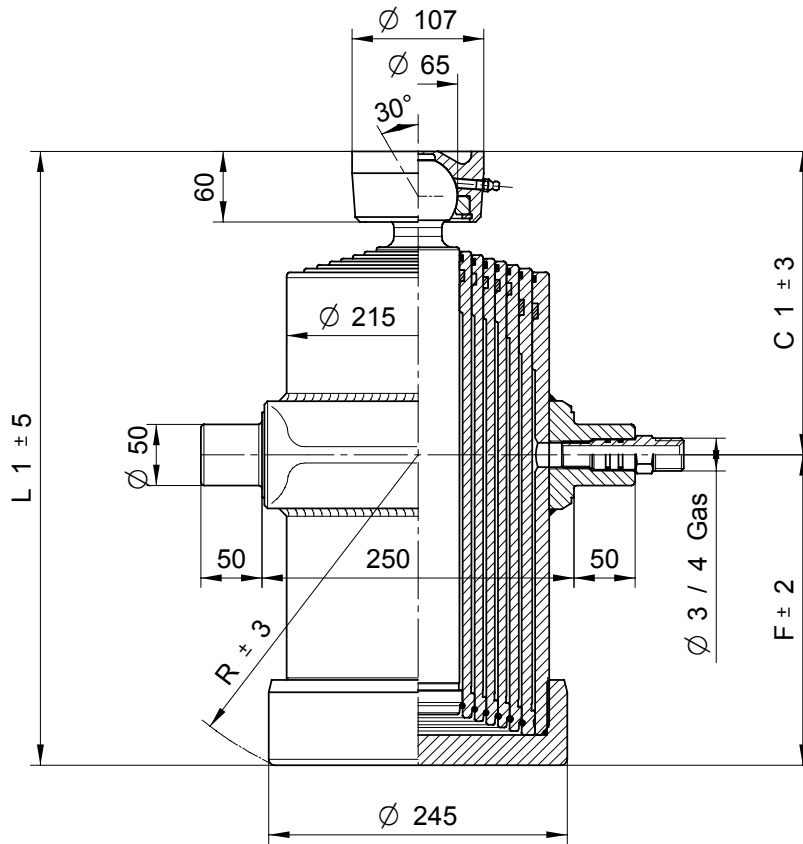

TYPE S :
SFERA
GÖMBÖS
BALL
KUGEL

OPCIÓK

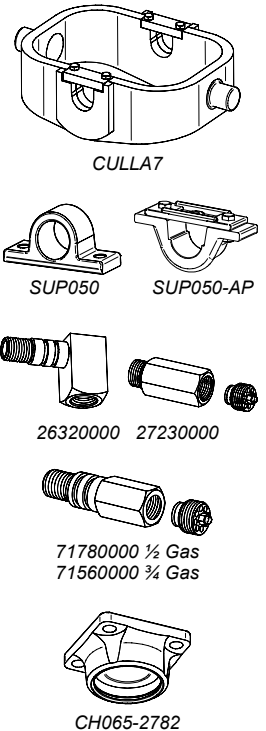

PESO TOT. RIBALTABILE 22 Ton. a 180 Bar

TOTAL WEIGHT TIP-UP 22 Ton. 180 Bar

ÖSSZTEHERBÍRÁS 22 TONNA 180BAR MELLETT

GESAMTGEWICHT KIPPANHÄNGER 22 Ton. 180 Bar

TIPO TÍPUS TYPE	DISEGNO - DRAWING RAJZ - ZEICHNUNG	CORSA - STROKE LÖKET - HUB	Ø SFILATE mm Ø TAGOK mm Ø EXTENSIONS mm Ø STUFEN mm								DIMENSIONI CILINDRO MUNKAHENGER MÉRETEI CYLINDER DIMENSIONS ZYLINDER ABMESSUNGEN						L. sfilata - L. extension Tagok hossza - L. stufen	Peso - Kg - Weight		Volume oil Lt. Amount of oil Lt. Olajmennyiség - Liter Ölínhalt Lt.	
			68 TON. 6,5	88 TON. 10,9	107 TON. 16,1	126 TON. 22,4	145 TON. 29,7	165 TON. 38,4	187 TON. 49,4	210 TON. 62,3	236 TON. 78,5	C	C'	F	L	L'		R	F		S
7050	14020	1665	●	●	●	●	●	●	●			-	250	195	-	445	230	320	-	102	23
7051	14021	1770	●	●	●	●	●	●	●			-	250	210	-	460	244	335	-	106	24
7052	14022	2065	●	●	●	●	●	●	●			-	250	255	-	505	283	380	-	116	29
7053	14023	2550	●	●	●	●	●	●	●			-	250	325	-	575	348	450	-	132	35
7054	14024	2905	●	●	●	●	●	●	●			-	250	375	-	625	395	500	-	144	40
7055	14025	3395	●	●	●	●	●	●	●			-	250	445	-	695	462	570	-	160	47
7057	14027	2340	●	●	●	●	●	●	●			-	250	295	-	545	318	420	-	121	32

PRESSIONE MAX. DI ESERCIZIO 180 BAR - MAXIMÁLIS NYOMÁS 180 BAR
WORKING MAX. PRESSURE 180 BAR - MAX. BETRIEBSDRUCK 180 BAR

CILINDRI TELESCOPICI CON 7 SFILATE
TELESCOPIC CYLINDERS WITH 7 EXTENSIONS

TELESZKÓPOS MUNKAHENGER 7 TAGÚ
TELESKOPZYLINDER MIT 7 VERLÄNGERUNGEN

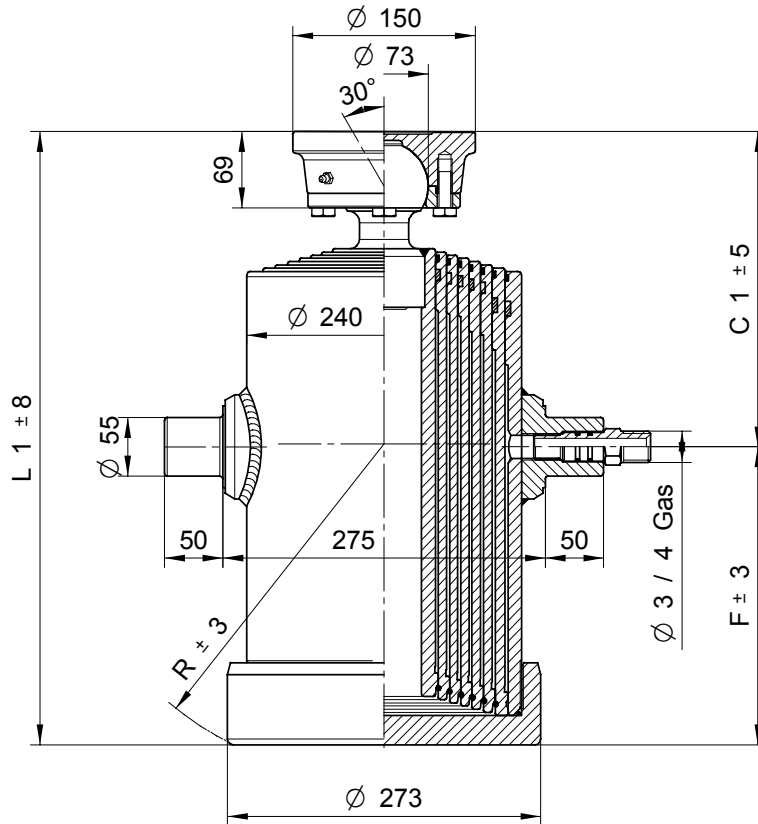

TYPE S :
SFERA
GÖMBÖS
BALL
KUGEL

OPCIÓK

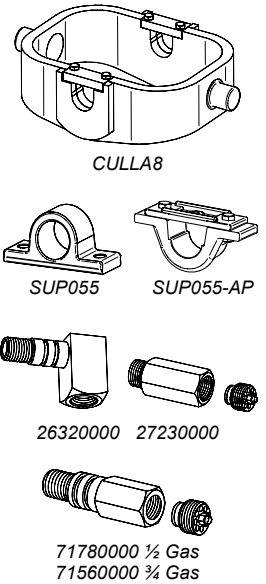

PESO TOT. RIBALTABILE 25 Ton. a 180 Bar

TOTAL WEIGHT TIP-UP 25 Ton. 180 Bar

ÖSSZTEHERBÍRÁS 25 TONNA 180BAR MELLETT

GESAMTGEWICHT KIPPANHÄNGER 25 Ton. 180 Bar

TIPO TÍPUS TYPE TYP	DISEGNO - DRAWING RAJZ - ZEICHNUNG	CORSA - STROKE LÖKET - HUB	Ø SFILATE mm Ø TAGOK mm Ø EXTENSIONS mm Ø STUFEN mm								DIMENSIONI CILINDRO MUNKAHENGER MÉRETEI CYLINDER DIMENSIONS ZYLINDER ABMESSUNGEN						L. sfilata - L. extension Tagok hossza - L. stufen	Peso - Kg - Weight		Volume oil Lt. Amount of oil Lt. Olajmennyiség - Liter Ölínhalt Lt.
			68 TON. 6,5	88 TON. 10,9	107 TON. 16,1	126 TON. 22,4	145 TON. 29,7	165 TON. 38,4	187 TON. 49,4	210 TON. 62,3	236 TON. 78,5	C	C'	F	L	L'		R	F	
7029	12829	1492	●	●	●	●	●	●	●	●	-	233	205	-	438	248	300	-	112	27
7030	12830	1632	●	●	●	●	●	●	●	●	-	233	225	-	458	265	320	-	120	29
7031	12831	1737	●	●	●	●	●	●	●	●	-	233	240	-	473	277	335	-	125	31
7032	12832	1992	●	●	●	●	●	●	●	●	-	253	265	-	518	300	380	-	136	35
7033	12833	2270	●	●	●	●	●	●	●	●	-	253	305	-	558	335	420	-	147	40
7034	12834	2482	●	●	●	●	●	●	●	●	-	253	335	-	588	364	450	-	155	44
7035	12835	2832	●	●	●	●	●	●	●	●	-	253	385	-	638	410	500	-	168	50
7036	12836	3112	●	●	●	●	●	●	●	●	-	253	425	-	678	448	540	-	181	55
7037	12837	3322	●	●	●	●	●	●	●	●	-	253	455	-	708	478	570	-	198	59

PRESSIONE MAX. DI ESERCIZIO 180 BAR - MAXIMÁLIS NYOMÁS 180 BAR
WORKING MAX. PRESSURE 180 BAR - MAX. BETRIEBSDRUCK 180 BAR

CILINDRI TELESCOPICI CON 7 SFILATE
TELESCOPIC CYLINDERS WITH 7 EXTENSIONS

TELESZKÓPOS MUNKAHENGER 7 TAGÚ
TELESKOPZYLINDER MIT 7 VERLÄNGERUNGEN

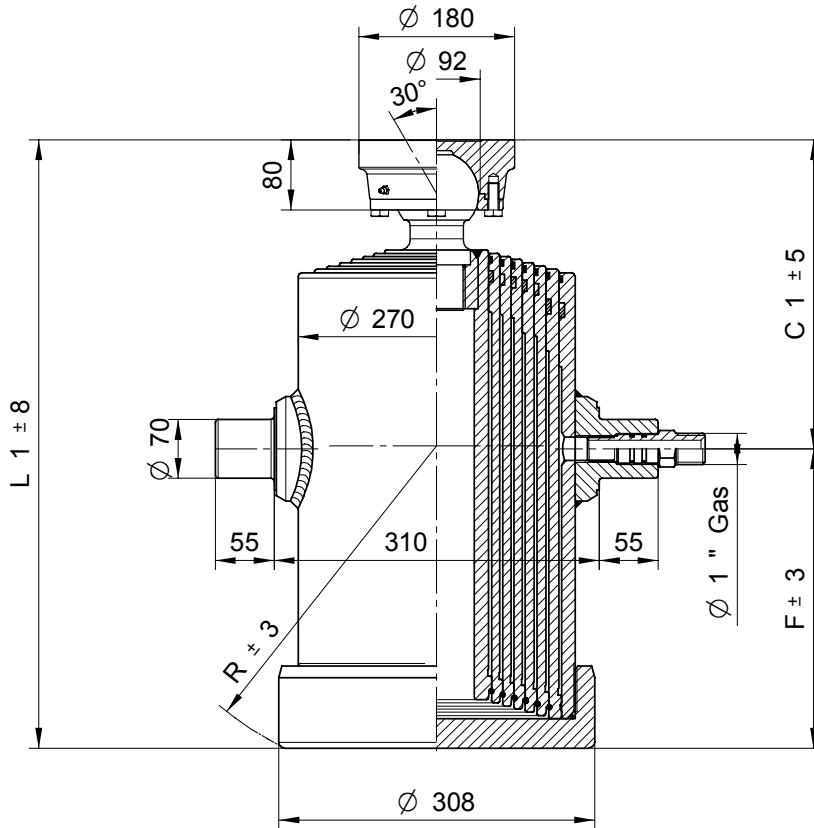

TYPE S :
SFERA
GÖMBÖS
BALL
KUGEL

OPCIÓK

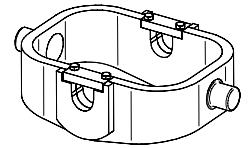

CULLA9

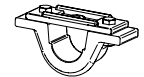

SUP070-AP

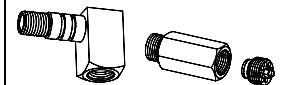

26790000 27240000

PESO TOT. RIBALTABILE 38 Ton. a 180 Bar

TOTAL WEIGHT TIP-UP 38 Ton. 180 Bar

ÖSSZTEHERBÍRÁS 38 TONNA 180BAR MELLETT

GESAMTGEWICHT KIPPANHÄNGER 38 Ton. 180 Bar

TIPO TÍPUS TYPE TYP	DISEGNO - DRAWING RAJZ - ZEICHNUNG	CORSA - STROKE LÖKET - HUB	Ø SFILATE mm Ø TAGOK mm Ø EXTENSIONS mm Ø STUFEN mm								DIMENSIONI CILINDRO MUNKAHENGER MÉRETEI CYLINDER DIMENSIONS ZYLINDER ABMESSUNGEN						L. sfilata - L. extension Tagok hossza - L. stufen	Peso - Kg - Weight		Volume oil Lt. Amount of oil Lt. Olajmennyiség - Liter Ölinhalt Lt.		
			88 TON. 10,9	107 TON. 16,1	126 TON. 22,4	145 TON. 29,7	165 TON. 38,4	187 TON. 49,4	210 TON. 62,3	236 TON. 78,5	265 TON. 99,2	C	C'	F	L	L'		R	F		S	
7059	14879	1442		●	●	●	●	●	●	●	●		-	253	209	-	462	260	300	-	149	32,8
7060	14880	1582		●	●	●	●	●	●	●	●		-	253	229	-	482	276	320	-	155	36,2
7061	14881	1687		●	●	●	●	●	●	●	●		-	253	244	-	497	289	335	-	160	38,4
7062	14882	1912		●	●	●	●	●	●	●	●		-	273	269	-	542	310	380	-	175	42,8
7063	14883	2192		●	●	●	●	●	●	●	●		-	273	309	-	582	346	420	-	189	49,4
7064	14884	2402		●	●	●	●	●	●	●	●		-	273	339	-	612	373	450	-	204	54,4
7065	14885	2752		●	●	●	●	●	●	●	●		-	273	389	-	662	419	500	-	228	62,7
7066	14886	3032		●	●	●	●	●	●	●	●		-	273	429	-	702	456	540	-	248	69,3
7067	14887	3242		●	●	●	●	●	●	●	●		-	273	459	-	732	484	570	-	264	74,3

PRESSIONE MAX. DI ESERCIZIO 180 BAR - MAXIMÁLIS NYOMÁS 180 BAR
WORKING MAX. PRESSURE 180 BAR - MAX. BETRIEBSDRUCK 180 BAR

CILINDRI TELESCOPICI CON 7 SFILATE
TELESCOPIC CYLINDERS WITH 7 EXTENSIONS

TELESZKÓPOS MUNKAHENGER 7 TAGÚ
TELESKOPZYLINDER MIT 7 VERLÄNGERUNGEN

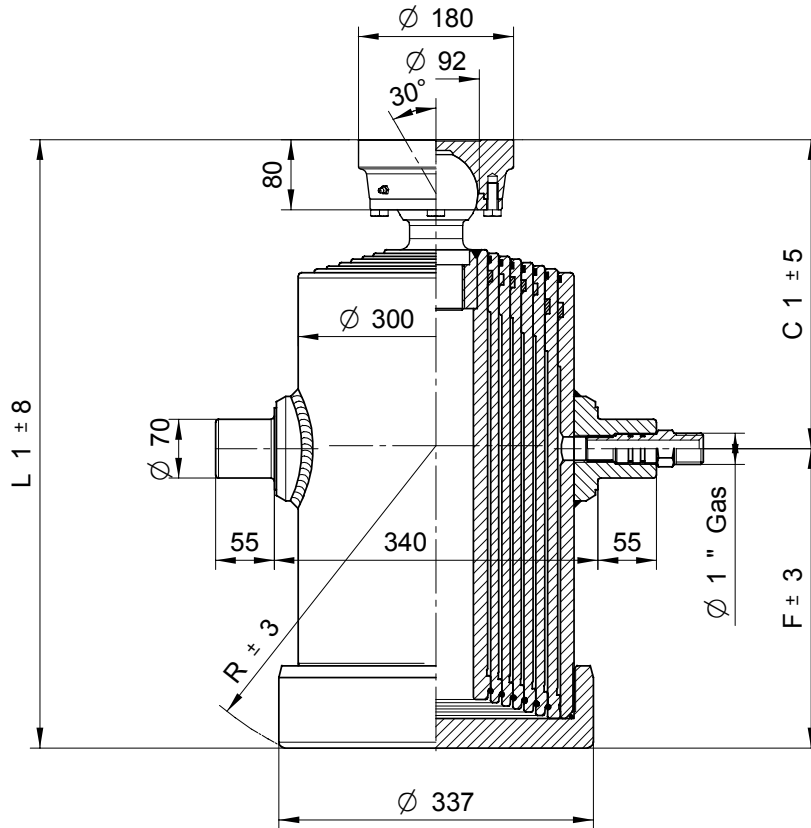

TYPE S :
SFERA
GÖMBÖS
BALL
KUGEL

OPCIÓK

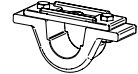

SUP070-AP

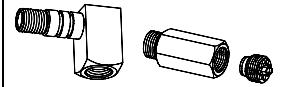

26790000 27240000

PESO TOT. RIBALTABILE 42 Ton. a 180 Bar

TOTAL WEIGHT TIP-UP 42 Ton. 180 Bar

ÖSSZTEHERBÍRÁS 42 TONNA 180BAR MELLETT

GESAMTGEWICHT KIPPANHÄNGER 42 Ton. 180 Bar

TIPO TÍPUS TYPE TYP	DISEGNO - DRAWING RAJZ - ZEICHNUNG	CORSA - STROKE LÖKET - HUB	Ø SFILATE mm Ø TAGOK mm Ø EXTENSIONS mm Ø STUFEN mm								DIMENSIONI CILINDRO MUNKAHENGER MÉRETEI CYLINDER DIMENSIONS ZYLINDER ABMESSUNGEN						L. sfilata - L. extension Tagok hossza - L. stufen	Peso - Kg - Weight Tömeg - Kg - Gewicht	Volume oil Lt. Amount of oil Lt. Olajmennyiség - Liter Olinhalt Lt.	
			88 TON. 10,9	107 TON. 16,1	126 TON. 22,4	145 TON. 29,7	165 TON. 38,4	187 TON. 49,4	210 TON. 62,3	236 TON. 78,5	265 TON. 99,2	C	C'	F	L	L'				R
			F	S																
7079	14899	1387		●	●	●	●	●	●	●	-	253	212	-	465	272	300	-	188	40,4
7080	14900	1527		●	●	●	●	●	●	●	-	253	232	-	485	288	320	-	195	44,6
7081	14901	1632		●	●	●	●	●	●	●	-	253	247	-	500	300	335	-	200	47,8
7082	14902	1837		●	●	●	●	●	●	●	-	273	272	-	545	321	380	-	218	52,9
7083	14903	2117		●	●	●	●	●	●	●	-	273	312	-	585	355	420	-	234	61,4
7084	14904	2327		●	●	●	●	●	●	●	-	273	342	-	615	382	450	-	250	67,7
7085	14905	2677		●	●	●	●	●	●	●	-	273	392	-	665	273	500	-	270	78,3
7086	14906	2957		●	●	●	●	●	●	●	-	273	432	-	705	464	540	-	284	86,8
7087	14907	3167		●	●	●	●	●	●	●	-	273	462	-	735	492	570	-	300	93
7091	14911	4534		●	●	●	●	●	●	●	-	273	642	-	915	664	750	-	364	130

PRESSIONE MAX. DI ESERCIZIO 180 BAR - MAXIMÁLIS NYOMÁS 180 BAR
WORKING MAX. PRESSURE 180 BAR - MAX. BETRIEBSDRUCK 180 BAR

CILINDRI TELESCOPICI CON 8 SFILATE
TELESCOPIC CYLINDERS WITH 8 EXTENSIONS

TELESZKÓPOS MUNKAHENGER 8 TAGÚ
TELESKOPZYLINDER MIT 8 VERLÄNGERUNGEN

TYPE F :
FORO
FURATOS
HOLE
LOCH

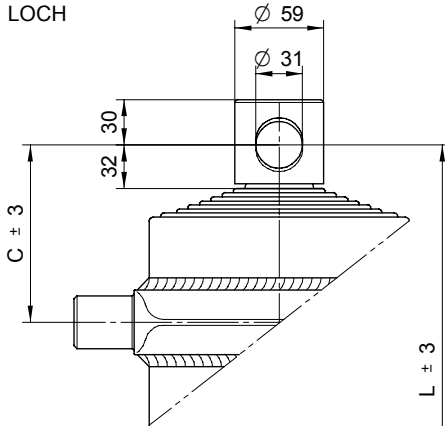

TYPE S :
SFERA
GÖMBÖS
BALL
KUGEL

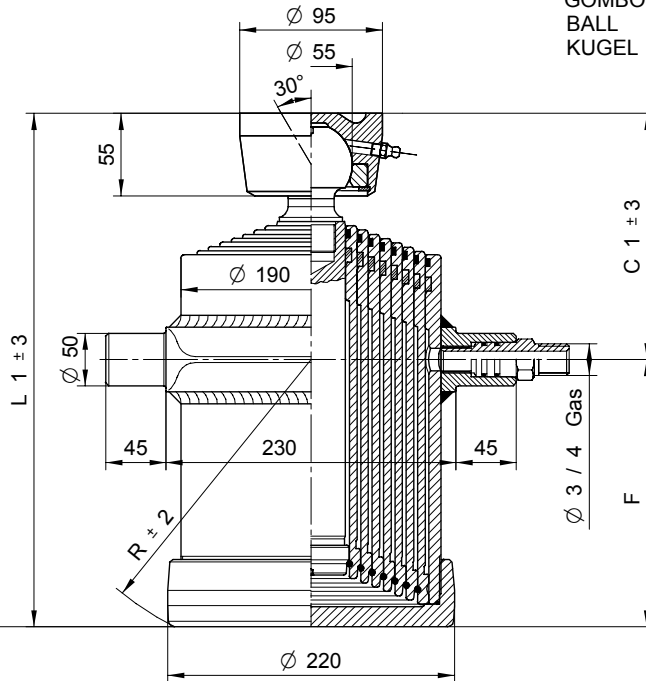

OPCIÓK

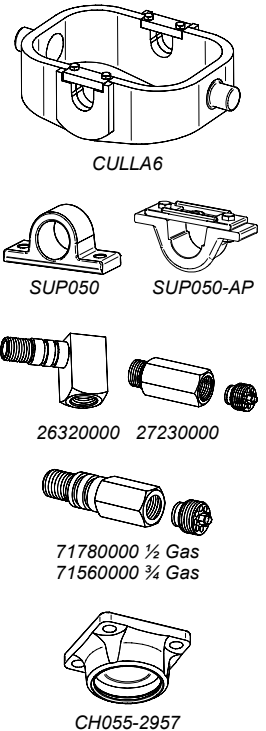

PESO TOT. RIBALTABILE 11 Ton. a 180 Bar
ÖSSZTEHERBÍRÁS 11 TONNA 180BAR MELLETT

TOTAL WEIGHT TIP-UP 11 Ton. 180 Bar
GESAMTGEWICHT KIPPANHÄNGER 11 Ton. 180 Bar

TIPO TÍPUS TYPE TYP	DISEGNO - DRAWING RAJZ - ZEICHNUNG	CORSA - STROKE LÖKET - HUB	Ø SFILATE mm Ø TAGOK mm Ø EXTENSIONS mm Ø STUFEN mm								DIMENSIONI CILINDRO MUNKAHENGER MÉRETEI CYLINDER DIMENSIONS ZYLINDER ABMESSUNGEN						L. sfilata - L. extension Tagok hossza - L. stufen	Peso - Kg - Weight Tömeg - Kg - Gewicht		Volume oil Lt. Amount of oil Lt. Olajmennyiség - Liter Ölínhalt Lt.		
			30 TON. 1,1	46 TON. 2,9	61 TON. 5,2	76 TON. 8,1	91 TON. 11,7	107 TON. 16,1	126 TON. 22,4	145 TON. 29,7	165 TON. 38,4	C	C'	F	L	L'		R	F		S	
8002	9325	1540	●	●	●	●	●	●	●	●	●	●	130	180	212	342	392	240	270	67	69	15
8003	9319	1730	●	●	●	●	●	●	●	●	●	●	200	250	162	362	412	196	290	71	73	17
8004	9321	1940	●	●	●	●	●	●	●	●	●	●	200	250	192	392	442	222	320	76	78	19,5
8005	9322	2060	●	●	●	●	●	●	●	●	●	●	200	250	207	407	457	235	335	78	80	20,5
8006	9323	2340	●	●	●	●	●	●	●	●	●	●	200	250	242	442	492	265	370	84	86	22,5
8007	9324	2980	●	●	●	●	●	●	●	●	●	●	200	250	322	522	572	340	450	98	100	28,7

PRESSIONE MAX. DI ESERCIZIO 180 BAR - MAXIMÁLIS NYOMÁS 180 BAR
WORKING MAX. PRESSURE 180 BAR - MAX. BETRIEBSDRUCK 180 BAR

CILINDRI TELESCOPICI CON 8 SFILATE
TELESCOPIC CYLINDERS WITH 8 EXTENSIONS

TELESZKÓPOS MUNKAHENGER 8 TAGÚ
TELESKOPZYLINDER MIT 8 VERLÄNGERUNGEN

TYPE F :
FORO
FURATOS
HOLE
LOCH

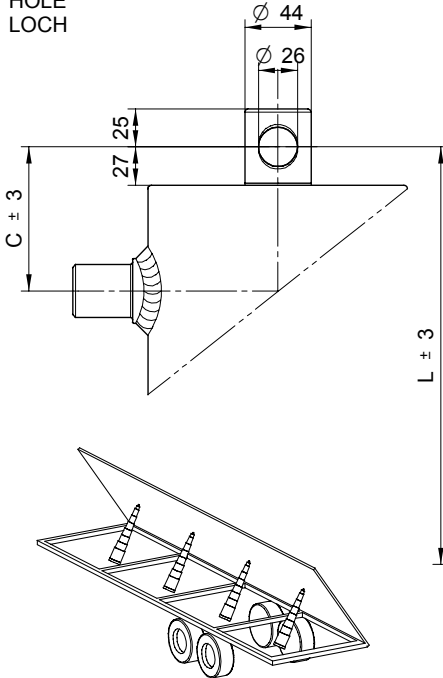

TYPE S :
SFERA
GÖMBÖS
BALL
KUGEL

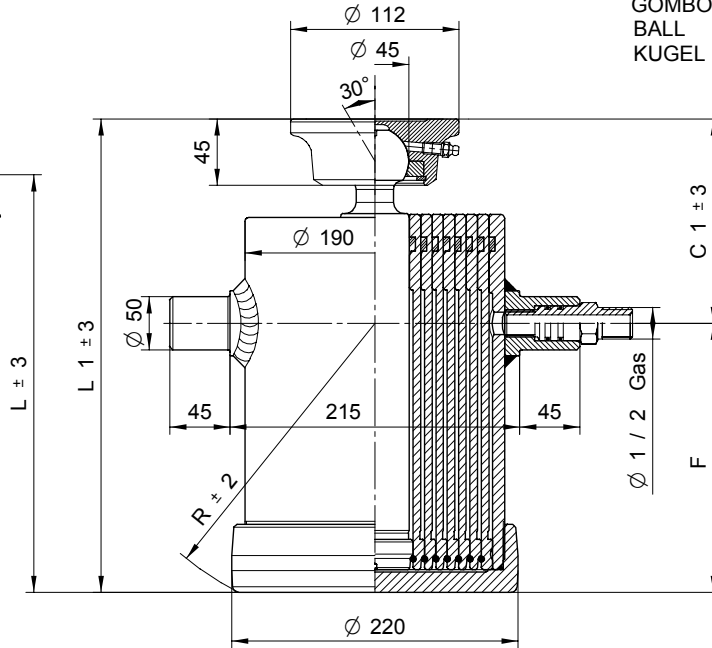

OPCIÓK

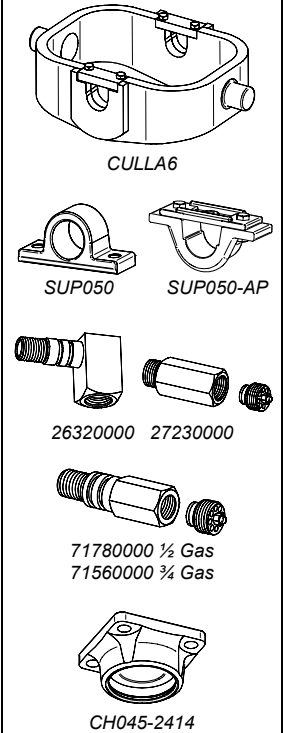

PESO TOT. RIBALTABILE 11 Ton. a 180 Bar
ÖSSZTEHERBÍRÁS 11 TONNA 180BAR MELLETT

TOTAL WEIGHT TIP-UP 11 Ton. 180 Bar
GESAMTGEWICHT KIPPANHÄNGER 11 Ton. 180 Bar

TIPO TÍPUS TYPE TYP	DISEGNO - DRAWING RAJZ - ZEICHNUNG	CORSA - STROKE LÖKET - HUB	Ø SFILATE mm Ø TAGOK mm Ø EXTENSIONS mm Ø STUFEN mm								DIMENSIONI CILINDRO MUNKAHENGER MÉRETEI CYLINDER DIMENSIONS ZYLINDER ABMESSUNGEN						L. sfilata - L. extension Tagok hossza - L. stufen	Peso - Kg - Weight Tömeg - Kg - Gewicht		Volume olio Lt. Amount of oil Lt. Olajmennyiség - Liter Ölinhalt Lt.								
			30 TON. 1,1	46 TON. 2,9	61 TON. 5,2	76 TON. 8,1	91 TON. 11,7	107 TON. 16,1	126 TON. 22,4	145 TON. 29,7	165 TON. 38,4	C	C'	F	L	L'		R	F		S							
			8000	9060	1000		●	●	●	●	●	●	●	●	●	●		●	●		●	105	145	145	250	290	185	200
8001	9250	1320		●	●	●	●	●	●	●	●	●	●	●	●	●	105	145	185	290	330	215	240	61	63	12,8		

PRESSIONE MAX. DI ESERCIZIO 180 BAR - MAXIMÁLIS NYOMÁS 180 BAR
WORKING MAX. PRESSURE 180 BAR - MAX. BETRIEBSDRUCK 180 BAR

CARATTERISTICHE TECNICHE DATE A TITOLO PURAMENTE INDICATIVO E MODIFICABILI SENZA PREAVVISO - THESE TECHNICAL SPECIFICATIONS ARE ONLY APPROXIMATE VALUES AND MAY BE CHANGED WITHOUT ANY PREVIOUS NOTICE
AZ ADATOK TÁJÉKOZTATÓ JELLEGŰEK, AZOKTÓL ELŐZETES FELHÍVÁS NÉLKÜL IS ELTÉRHETNEK - DIESE TECHNISHEN DATEN GELTEN NUR ALS RICHTWERTE UND KÖNNEN OHNE VORANMELDUNG GEÄNDERT WERDEN

CILINDRI TELESCOPICI CON 8 SFILATE
TELESCOPIC CYLINDERS WITH 8 EXTENSIONS

TELESZKÓPOS MUNKAHENGER 8 TAGÚ
TELESKOPZYLINDER MIT 8 VERLÄNGERUNGEN

TYPE F :
FORO
FURATOS
HOLE
LOCH

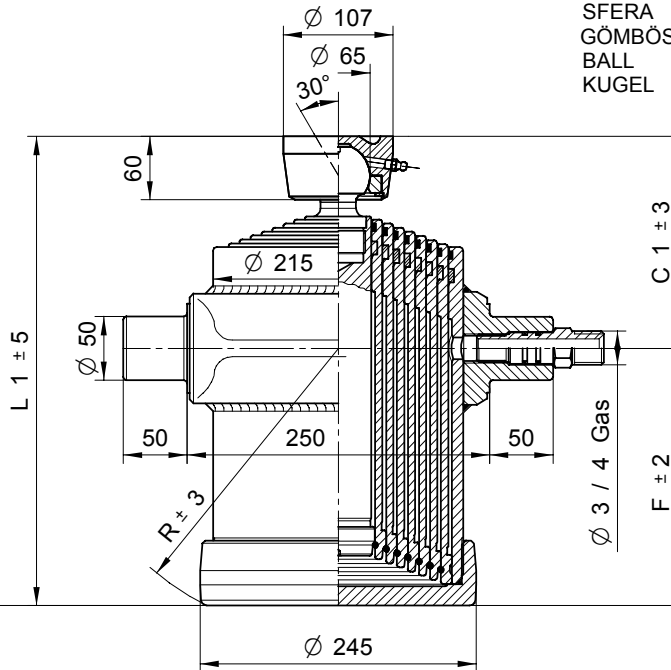
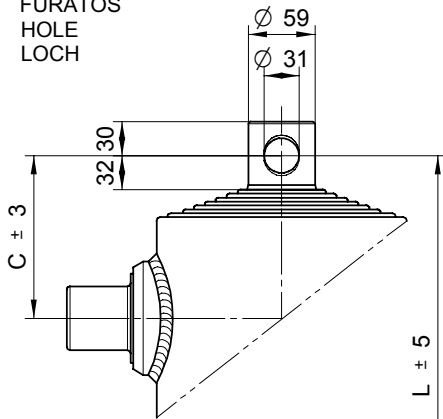

TYPE S :
SFERA
GÖMBÖS
BALL
KUGEL

OPCIÓK

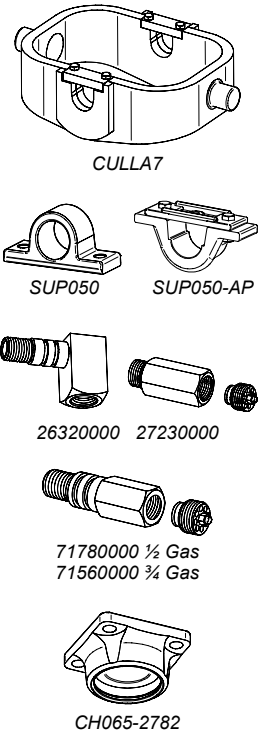

PESO TOT. RIBALTABILE 18 Ton. a 180 Bar

TOTAL WEIGHT TIP-UP 18 Ton. 180 Bar

ÖSSZTEHERBÍRÁS 18 TONNA 180BAR MELLETT

GESAMTGEWICHT KIPPANHÄNGER 18 Ton. 180 Bar

TIPO TÍPUS TYPE TYP	DISEGNO - DRAWING RAJZ - ZEICHNUNG	CORSA - STROKE LÖKET - HUB	Ø SFILATE mm Ø TAGOK mm Ø EXTENSIONS mm Ø STUFEN mm								DIMENSIONI CILINDRO MUNKAHENGER MÉRETEI CYLINDER DIMENSIONS ZYLINDER ABMESSUNGEN						L. sfilata - L. extension Tagok hossza - L. stufen	Peso - Kg - Weight		Volume oil Lt. Amount of oil Lt. Olajmennyiség - Liter Ölínhalt Lt.	
			46 TON. 2,9	61 TON. 5,2	76 TON. 8,1	91 TON. 11,7	107 TON. 16,1	126 TON. 22,4	145 TON. 29,7	165 TON. 38,4	187 TON. 49,4	C	C'	F	L	L'		R	F		S
8019	14075	1750	●	●	●	●	●	●	●	●	●	210	260	175	385	435	215	300	95	97	22
8020	14076	1910	●	●	●	●	●	●	●	●	●	210	260	195	405	455	230	320	101	103	24
8021	14077	2030	●	●	●	●	●	●	●	●	●	210	260	210	420	470	245	335	105	107	25
8022	14078	2310	●	●	●	●	●	●	●	●	●	210	260	245	455	505	275	370	116	118	29
8023	14079	2690	●	●	●	●	●	●	●	●	●	210	260	295	505	555	320	420	130	132	34
8024	14080	2930	●	●	●	●	●	●	●	●	●	210	260	325	535	585	350	450	140	142	37
8025	14081	3330	●	●	●	●	●	●	●	●	●	210	260	375	585	635	395	500	155	157	42
8027	14083	3890	●	●	●	●	●	●	●	●	●	210	260	445	655	705	465	570	176	178	49

PRESSIONE MAX. DI ESERCIZIO 180 BAR - MAXIMÁLIS NYOMÁS 180 BAR
WORKING MAX. PRESSURE 180 BAR - MAX. BETRIEBSDRUCK 180 BAR

CILINDRI TELESCOPICI CON 8 SFILATE
TELESCOPIC CYLINDERS WITH 8 EXTENSIONS

TELESZKÓPOS MUNKAHENGER 8 TAGÚ
TELESKOPZYLINDER MIT 8 VERLÄNGERUNGEN

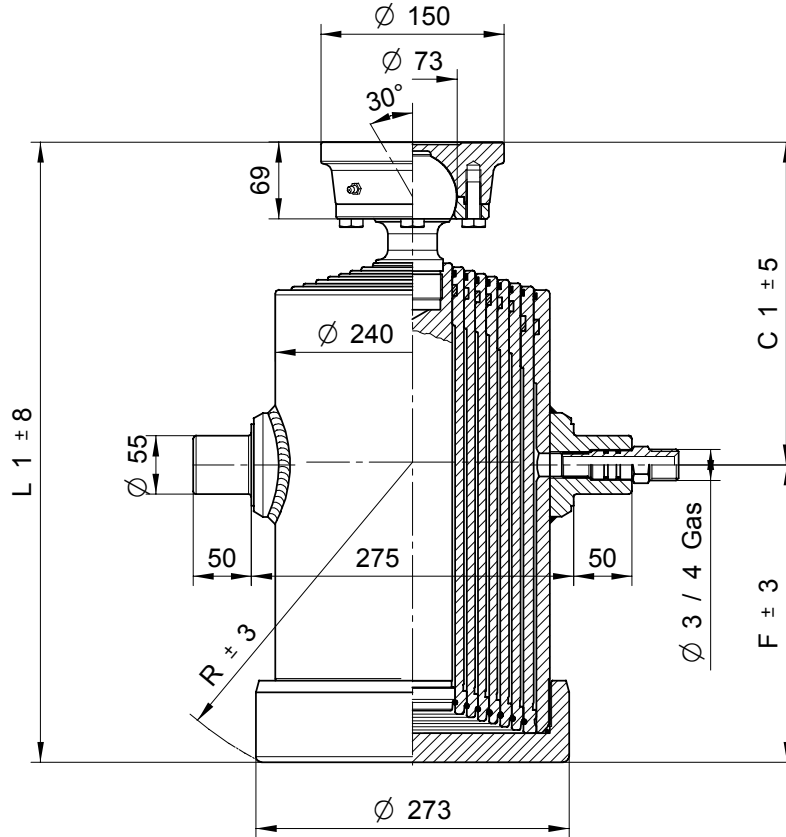

TYPE S :
SFERA
GÖMBÖS
BALL
KUGEL

OPCIÓK

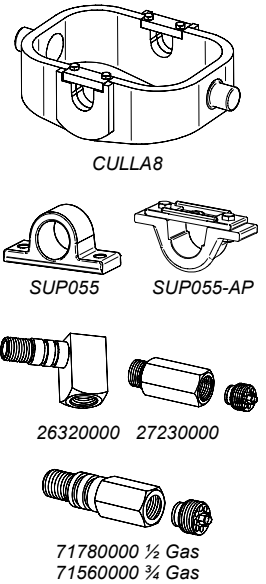

PESO TOT. RIBALTABILE 25 Ton. a 180 Bar

TOTAL WEIGHT TIP-UP 25 Ton. 180 Bar

ÖSSZTEHERBÍRÁS 25 TONNA 180BAR MELLETT

GESAMTGEWICHT KIPPANHÄNGER 25 Ton. 180 Bar

TIPO TÍPUS TYPE	DISEGNO - DRAWING RAJZ - ZEICHNUNG	CORSA - STROKE LÖKET - HUB	Ø SFILATE mm Ø TAGOK mm Ø EXTENSIONS mm Ø STUFEN mm								DIMENSIONI CILINDRO MUNKAHENGER MÉRETEI CYLINDER DIMENSIONS ZYLINDER ABMESSUNGEN						L. sfilata - L. extension Tagok hossza - L. stufen	Peso - Kg - Weight Tömeg - Kg - Gewicht		Volume oil Lt. Amount of oil Lt. Olajmennyiség - Liter Ölínhalt Lt.
			68 TON. 6,5	88 TON. 10,9	107 TON. 16,1	126 TON. 22,4	145 TON. 29,7	165 TON. 38,4	187 TON. 49,4	210 TON. 62,3	236 TON. 78,5	C	C'	F	L	L'		R	F	
8009	12850	1715	●	●	●	●	●	●	●	●	-	235	205	-	440	248	300	-	117	28
8010	12851	1875	●	●	●	●	●	●	●	●	-	235	225	-	460	265	320	-	126	30
8011	12852	1995	●	●	●	●	●	●	●	●	-	235	240	-	475	277	335	-	131	32
8012	12853	2295	●	●	●	●	●	●	●	●	-	255	265	-	520	300	380	-	145	36
8013	12854	2615	●	●	●	●	●	●	●	●	-	255	305	-	560	335	420	-	156	41
8014	12855	2855	●	●	●	●	●	●	●	●	-	255	335	-	590	364	450	-	165	45
8015	12856	3255	●	●	●	●	●	●	●	●	-	255	385	-	640	410	500	-	180	52
8016	12857	3575	●	●	●	●	●	●	●	●	-	255	425	-	680	448	540	-	194	57
8017	12858	3815	●	●	●	●	●	●	●	●	-	255	455	-	710	478	570	-	214	61

PRESSIONE MAX. DI ESERCIZIO 180 BAR - MAXIMÁLIS NYOMÁS 180 BAR
WORKING MAX. PRESSURE 180 BAR - MAX. BETRIEBSDRUCK 180 BAR

CILINDRI TELESCOPICI CON 8 SFILATE
TELESCOPIC CYLINDERS WITH 8 EXTENSIONS

TELESZKÓPOS MUNKAHENGER 8 TAGÚ
TELESKOPZYLINDER MIT 8 VERLÄNGERUNGEN

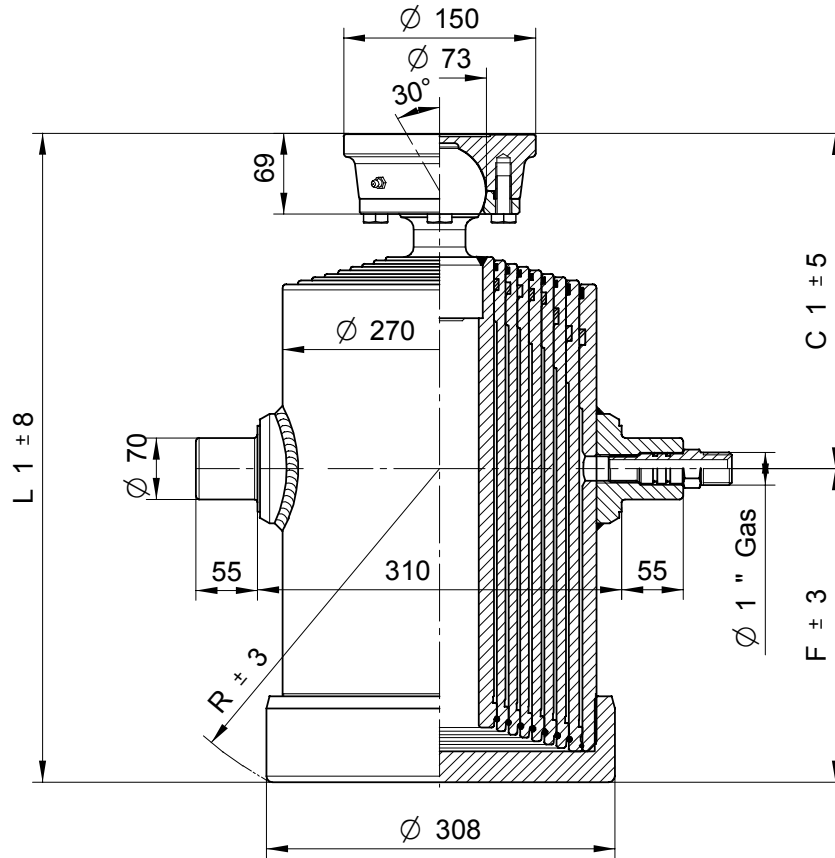

TYPE S :
SFERA
GÖMBÖS
BALL
KUGEL

OPCIÓK

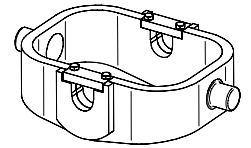

CULLA9

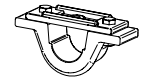

SUP070-AP

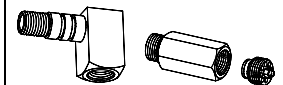

26790000 27240000

PESO TOT. RIBALTABILE 30 Ton. a 180 Bar

TOTAL WEIGHT TIP-UP 30 Ton. 180 Bar

ÖSSZTEHERBÍRÁS 30 TONNA 180BAR MELLETT

GESAMTGEWICHT KIPPANHÄNGER 30 Ton. 180 Bar

TIPO TÍPUS TYPE TYP	DISEGNO - DRAWING RAJZ - ZEICHNUNG	CORSA - STROKE LÖKET - HUB	Ø SFILATE mm Ø TAGOK mm Ø EXTENSIONS mm Ø STUFEN mm								DIMENSIONI CILINDRO MUNKAHENGER MÉRETEI CYLINDER DIMENSIONS ZYLINDER ABMESSUNGEN						L. sfilata - L. extension Tagok hossza - L. stufen	Peso - Kg - Weight Tömeg - Kg - Gewicht		Volume oil Lt. Amount of oil Lt. Olajmennyiség - Liter Ölinhalt Lt.
			68 TON. 6,5	88 TON. 10,9	107 TON. 16,1	126 TON. 22,4	145 TON. 29,7	165 TON. 38,4	187 TON. 49,4	210 TON. 62,3	236 TON. 78,5	C	C'	F	L	L'		R	F	
8029	12871	1670	●	●	●	●	●	●	●	●	-	235	209	-	444	260	300	-	149	35
8030	12872	1830	●	●	●	●	●	●	●	●	-	235	229	-	464	276	320	-	155	38
8031	12873	1950	●	●	●	●	●	●	●	●	-	235	244	-	479	289	335	-	160	41
8032	12874	2220	●	●	●	●	●	●	●	●	-	255	269	-	524	312	380	-	175	45
8033	12875	2540	●	●	●	●	●	●	●	●	-	255	309	-	564	350	420	-	189	52
8034	12876	2780	●	●	●	●	●	●	●	●	-	255	339	-	594	375	450	-	204	57
8035	12877	3180	●	●	●	●	●	●	●	●	-	255	389	-	644	420	500	-	228	66
8036	12878	3500	●	●	●	●	●	●	●	●	-	255	429	-	684	460	540	-	248	73
8037	12879	3740	●	●	●	●	●	●	●	●	-	255	459	-	714	486	570	-	264	78

PRESSIONE MAX. DI ESERCIZIO 180 BAR - MAXIMÁLIS NYOMÁS 180 BAR
WORKING MAX. PRESSURE 180 BAR - MAX. BETRIEBSDRUCK 180 BAR

CILINDRI TELESCOPICI CON 8 SFILATE
TELESCOPIC CYLINDERS WITH 8 EXTENSIONS

TELESZKÓPOS MUNKAHENGER 8 TAGÚ
TELESKOPZYLINDER MIT 8 VERLÄNGERUNGEN

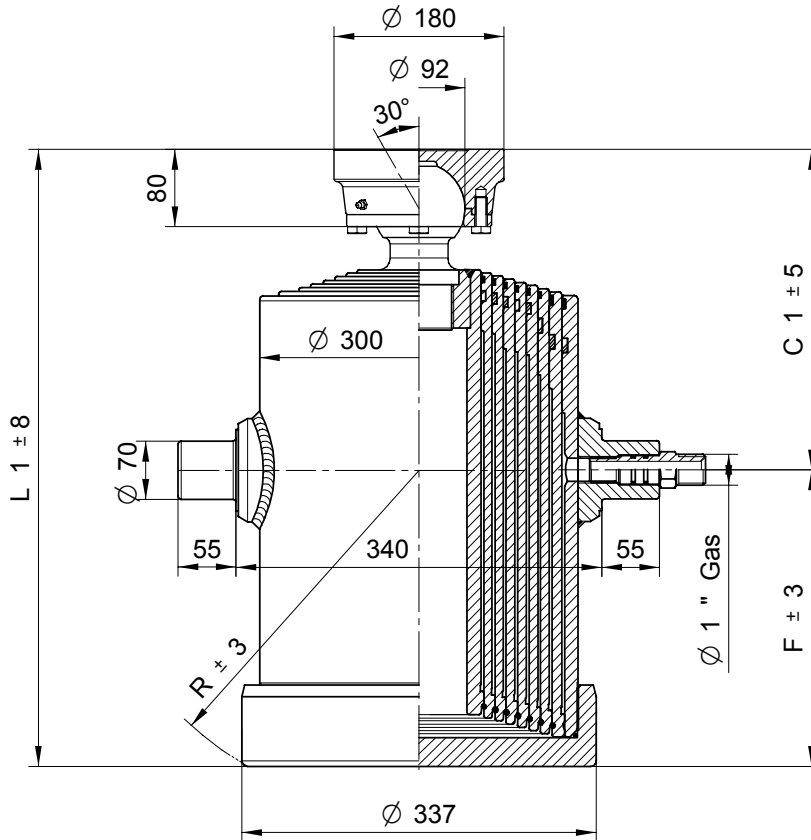

TYPE S :
SFERA
GÖMBÖS
BALL
KUGEL

OPCIÓK

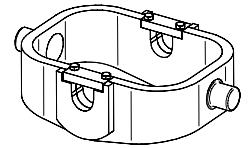

CULLA10

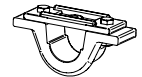

SUP070-AP

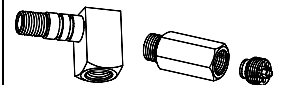

26790000 27240000

PESO TOT. RIBALTABILE 38 Ton. a 180 Bar

TOTAL WEIGHT TIP-UP 38 Ton. 180 Bar

ÖSSZTEHERBÍRÁS 38 TONNA 180BAR MELLETT

GESAMTGEWICHT KIPPANHÄNGER 38 Ton. 180 Bar

TIPO TÍPUS TYPE TYP	DISEGNO - DRAWING RAJZ - ZEICHNUNG	CORSA - STROKE LÖKET - HUB	Ø SFILATE mm Ø TAGOK mm Ø EXTENSIONS mm Ø STUFEN mm								DIMENSIONI CILINDRO MUNKAHENGER MÉRETEI CYLINDER DIMENSIONS ZYLINDER ABMESSUNGEN						L. sfilata - L. extension Tagok hossza - L. stufen	Peso - Kg - Weight Tömeg - Kg - Gewicht		Volume oil Lt. Amount of oil Lt. Olajmennyiség - Liter Ölínhalt Lt.		
			88 TON. 10,9	107 TON. 16,1	126 TON. 22,4	145 TON. 29,7	165 TON. 38,4	187 TON. 49,4	210 TON. 62,3	236 TON. 78,5	265 TON. 99,2	C	C'	F	L	L'		R	F		S	
8049	12920	1615		●	●	●	●	●	●	●	●	●	-	255	212	-	467	274	300	-	186	43
8050	12921	1775		●	●	●	●	●	●	●	●	●	-	255	232	-	487	290	320	-	193	48
8051	12922	1895		●	●	●	●	●	●	●	●	●	-	255	247	-	502	302	335	-	198	51
8052	12923	2145		●	●	●	●	●	●	●	●	●	-	275	272	-	547	324	380	-	216	57
8053	12924	2465		●	●	●	●	●	●	●	●	●	-	275	312	-	587	358	420	-	232	66
8054	12925	2705		●	●	●	●	●	●	●	●	●	-	275	342	-	617	384	450	-	248	72
8055	12926	3105		●	●	●	●	●	●	●	●	●	-	275	392	-	667	430	500	-	268	83
8056	12927	3425		●	●	●	●	●	●	●	●	●	-	275	432	-	707	466	540	-	282	92
8057	12928	3665		●	●	●	●	●	●	●	●	●	-	275	462	-	737	494	570	-	298	98

PRESSIONE MAX. DI ESERCIZIO 180 BAR - MAXIMÁLIS NYOMÁS 180 BAR
WORKING MAX. PRESSURE 180 BAR - MAX. BETRIEBSDRUCK 180 BAR

CILINDRI TELESCOPICI CON 9 SFILATE
TELESCOPIC CYLINDERS WITH 9 EXTENSIONS

TELESZKÓPOS MUNKAHENGER 9 TAGÚ
TELESKOPZYLINDER MIT 9 VERLÄNGERUNGEN

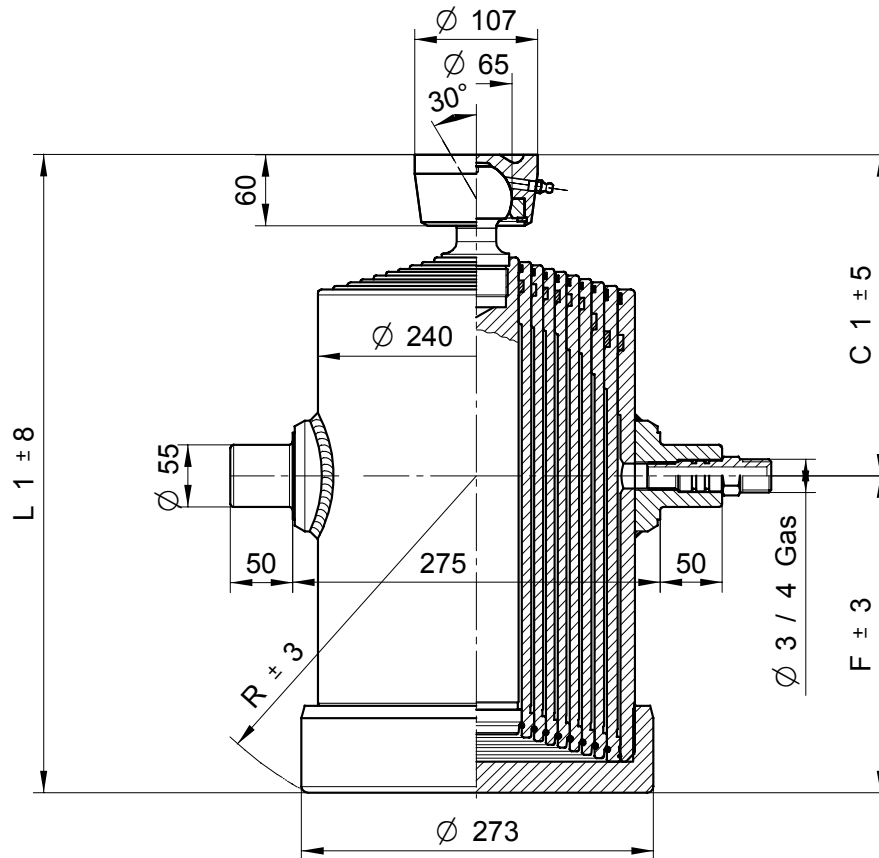

TYPE S :
SFERA
GÖMBÖS
BALL
KUGEL

OPCIÓK

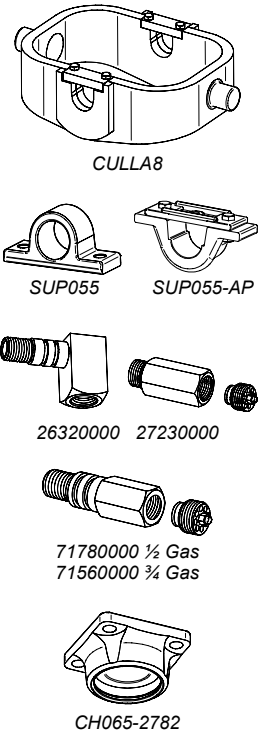

PESO TOT. RIBALTABILE 20 Ton. a 180 Bar

TOTAL WEIGHT TIP-UP 20 Ton. 180 Bar

ÖSSZTEHERBÍRÁS 20 TONNA 180BAR MELLETT

GESAMTGEWICHT KIPPANHÄNGER 20 Ton. 180 Bar

TIPO TÍPUS TYPE TYP	DISEGNO - DRAWING RAJZ - ZEICHNUNG	CORSA - STROKE LÖKET - HUB	Ø SFILATE mm Ø TAGOK mm Ø EXTENSIONS mm Ø STUFEN mm									DIMENSIONI CILINDRO MUNKAHENGER MÉRETEI CYLINDER DIMENSIONS ZYLINDER ABMESSUNGEN						L. sfilata - L. extension Tagok hossza - L. stufen	Peso - Kg - Weight		Volume oil Lt. Amount of oil Lt. Olajmennyiség - Liter Ölínhalt Lt.
			61 TON. 5,2	76 TON. 8,1	91 TON. 11,7	107 TON. 16,1	126 TON. 22,4	145 TON. 29,7	165 TON. 38,4	187 TON. 49,4	210 TON. 62,3	C	C'	F	L	L'	R		F	S	
9009	12885	1940	●	●	●	●	●	●	●	●	●	-	235	205	-	440	248	300	-	115	28,5
9010	12886	2120	●	●	●	●	●	●	●	●	●	-	235	225	-	460	265	320	-	124	31
9011	12887	2250	●	●	●	●	●	●	●	●	●	-	235	240	-	475	277	335	-	129	33
9012	12888	2600	●	●	●	●	●	●	●	●	●	-	255	265	-	520	300	370	-	141	37
9013	12889	2960	●	●	●	●	●	●	●	●	●	-	255	305	-	560	335	420	-	154	42,5
9014	12890	3230	●	●	●	●	●	●	●	●	●	-	255	335	-	590	364	450	-	163	46,5
9015	12891	3680	●	●	●	●	●	●	●	●	●	-	255	385	-	640	410	500	-	178	53,5
9016	12892	4040	●	●	●	●	●	●	●	●	●	-	255	425	-	680	448	540	-	190	59
9017	12893	4310	●	●	●	●	●	●	●	●	●	-	255	455	-	710	478	570	-	199	63

PRESSIONE MAX. DI ESERCIZIO 180 BAR - MAXIMÁLIS NYOMÁS 180 BAR
WORKING MAX. PRESSURE 180 BAR - MAX. BETRIEBSDRUCK 180 BAR

CILINDRI TELESCOPICI CON 9 SFILATE
TELESCOPIC CYLINDERS WITH 9 EXTENSIONS

TELESZKÓPOS MUNKAHENGER 9 TAGÚ
TELESKOPZYLINDER MIT 9 VERLÄNGERUNGEN

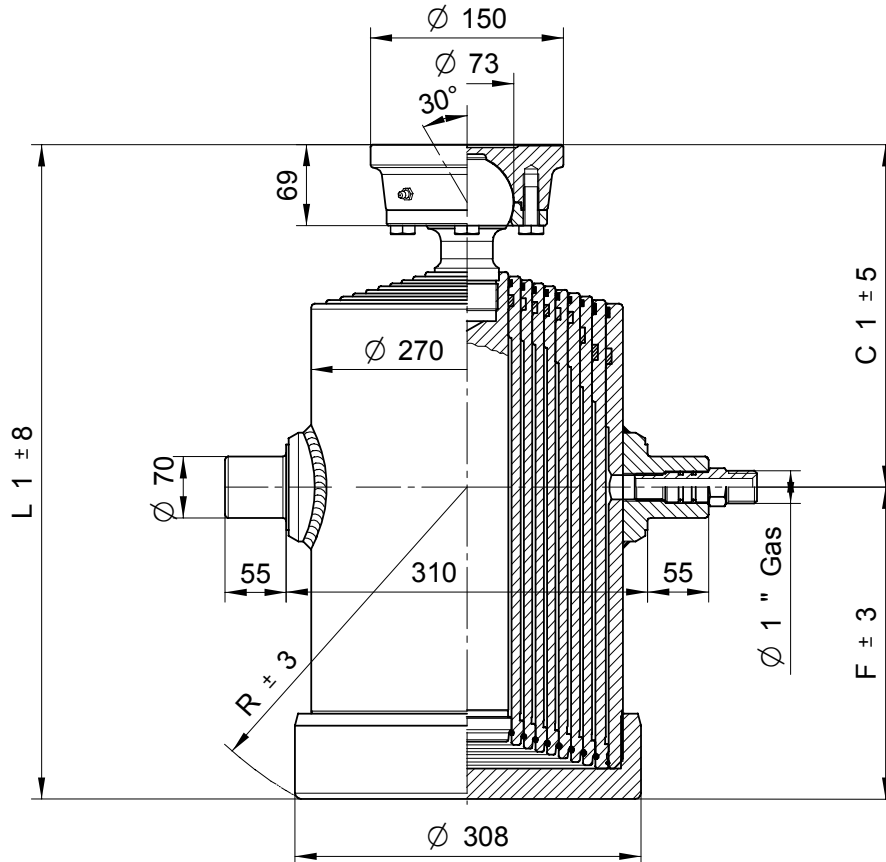

TYPE S :
SFERA
GÖMBÖS
BALL
KUGEL

OPCIÓK

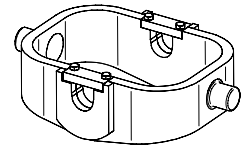

CULLA9



SUP070-AP

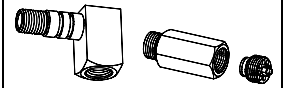

26790000 27240000

PESO TOT. RIBALTABILE 25 Ton. a 180 Bar

TOTAL WEIGHT TIP-UP 25 Ton. 180 Bar

ÖSSZTEHERBÍRÁS 25 TONNA 180BAR MELLETT

GESAMTGEWICHT KIPPANHÄNGER 25 Ton. 180 Bar

TIPO TÍPUS TYPE TYP	DISEGNO - DRAWING RAJZ - ZEICHNUNG	CORSA - STROKE LÖKET - HUB	Ø SFILATE mm Ø TAGOK mm Ø EXTENSIONS mm Ø STUFEN mm									DIMENSIONI CILINDRO MUNKAHENGER MÉRETEI CYLINDER DIMENSIONS ZYLINDER ABMESSUNGEN						L. sfilata - L. extension Tagok hossza - L. stufen	Peso - Kg - Weight		Volume oil Lt. Amount of oil Lt. Olajmennyiség - Liter Ölinhalt Lt.
			68 TON. 6,5	88 TON. 10,9	107 TON. 16,1	126 TON. 22,4	145 TON. 29,7	165 TON. 38,4	187 TON. 49,4	210 TON. 62,3	236 TON. 78,5	C	C'	F	L	L'	R		F	S	
9029	12895	1897	●	●	●	●	●	●	●	●	●	-	237	209	-	446	260	300	-	155	36
9030	12896	2077	●	●	●	●	●	●	●	●	●	-	237	229	-	466	276	320	-	161	39
9031	12897	2212	●	●	●	●	●	●	●	●	●	-	237	244	-	481	289	335	-	166	42
9032	12898	2527	●	●	●	●	●	●	●	●	●	-	257	269	-	526	312	380	-	183	47
9033	12899	2887	●	●	●	●	●	●	●	●	●	-	257	309	-	566	350	420	-	198	54
9034	12900	3157	●	●	●	●	●	●	●	●	●	-	257	339	-	596	375	450	-	214	59
9035	12901	3607	●	●	●	●	●	●	●	●	●	-	257	389	-	646	420	500	-	240	67
9036	12902	3967	●	●	●	●	●	●	●	●	●	-	257	429	-	686	460	540	-	264	75
9037	12903	4237	●	●	●	●	●	●	●	●	●	-	257	459	-	716	486	570	-	281	80

PRESSIONE MAX. DI ESERCIZIO 180 BAR - MAXIMÁLIS NYOMÁS 180 BAR
WORKING MAX. PRESSURE 180 BAR - MAX. BETRIEBSDRUCK 180 BAR

CILINDRI TELESCOPICI CON 9 SFILATE
TELESCOPIC CYLINDERS WITH 9 EXTENSIONS

TELESZKÓPOS MUNKAHENGER 9 TAGÚ
TELESKOPZYLINDER MIT 9 VERLÄNGERUNGEN

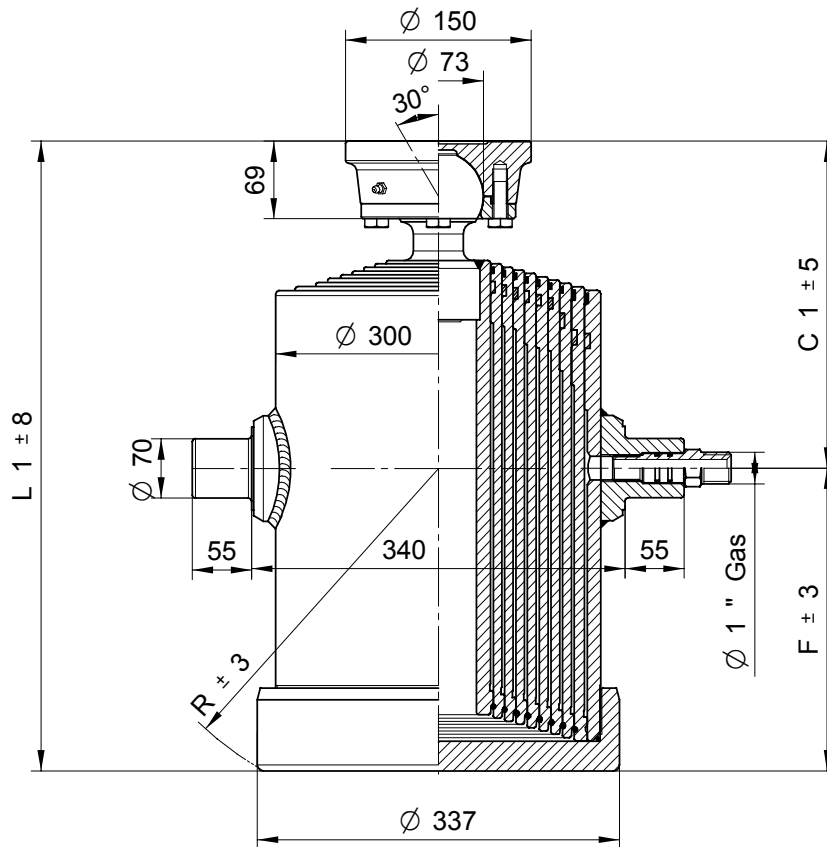

TYPE S :
SFERA
GÖMBÖS
BALL
KUGEL

OPCIÓK

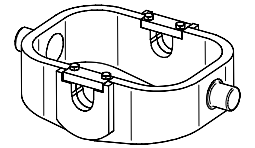

CULLA10

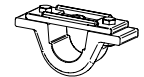

SUP070-AP

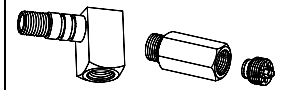

26790000 27240000

PESO TOT. RIBALTABILE 32 Ton. a 180 Bar

TOTAL WEIGHT TIP-UP 32 Ton. 180 Bar

ÖSSZTEHERBÍRÁS 32 TONNA 180BAR MELLETT

GESAMTGEWICHT KIPPANHÄNGER 32 Ton. 180 Bar

TIPO TÍPUS TYPE TYP	DISEGNO - DRAWING RAJZ - ZEICHNUNG	CORSA - STROKE LÖKET - HUB	Ø SFILATE mm Ø TAGOK mm Ø EXTENSIONS mm Ø STUFEN mm									DIMENSIONI CILINDRO MUNKAHENGER MÉRETEI CYLINDER DIMENSIONS ZYLINDER ABMESSUNGEN						L. sfilata - L. extension Tagok hossza - L. stufen	Peso - Kg - Weight Tömeg - Kg - Gewicht		Volume oil Lt. Amount of oil Lt. Olajmennyiség - Liter Ölinhalt Lt.
			88 TON. 10,9	107 TON. 16,1	126 TON. 22,4	145 TON. 29,7	165 TON. 38,4	187 TON. 49,4	210 TON. 62,3	236 TON. 78,5	265 TON. 99,2	C	C'	F	L	L'	R		F	S	
9049	12942	1842	●	●	●	●	●	●	●	●	●	-	237	212	-	449	274	300	-	188	45
9050	12943	2022	●	●	●	●	●	●	●	●	●	-	237	232	-	469	290	320	-	195	49
9051	12944	2155	●	●	●	●	●	●	●	●	●	-	237	247	-	484	302	335	-	202	53
9052	12945	2452	●	●	●	●	●	●	●	●	●	-	257	272	-	529	324	380	-	222	59
9053	12946	2812	●	●	●	●	●	●	●	●	●	-	257	312	-	569	358	420	-	238	68
9054	12947	3082	●	●	●	●	●	●	●	●	●	-	257	342	-	599	384	450	-	254	75
9055	12948	3532	●	●	●	●	●	●	●	●	●	-	257	392	-	649	430	500	-	274	86
9056	12949	3892	●	●	●	●	●	●	●	●	●	-	257	432	-	689	466	540	-	292	95
9057	12950	4162	●	●	●	●	●	●	●	●	●	-	257	462	-	719	494	570	-	307	102

PRESSIONE MAX. DI ESERCIZIO 180 BAR - MAXIMÁLIS NYOMÁS 180 BAR
WORKING MAX. PRESSURE 180 BAR - MAX. BETRIEBSDRUCK 180 BAR

CILINDRI TELESCOPICI CON 10 SFILATE
TELESCOPIC CYLINDERS WITH 10 EXTENSIONS

TELESZKÓPOS MUNKAHENGER 10 TAGÚ
TELESKOPZYLINDER MIT 10 VERLÄNGERUNGEN

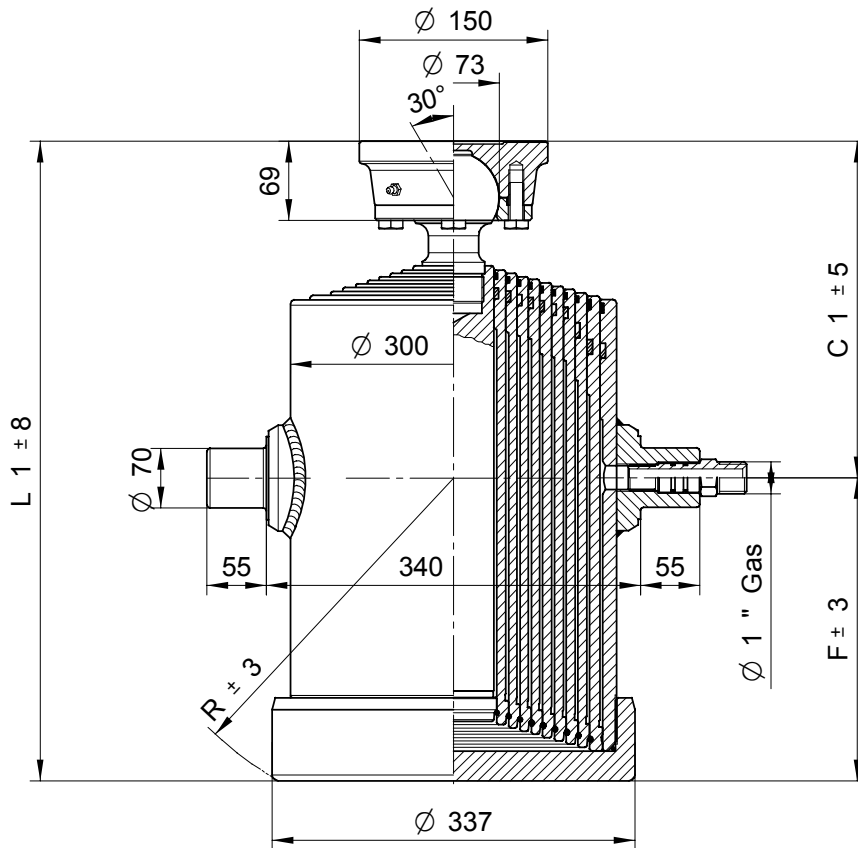

TYPE S :
SFERA
GÖMBÖS
BALL
KUGEL

OPCIÓK

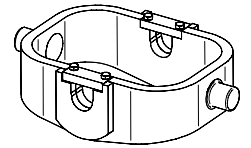

CULLA10



SUP070-AP

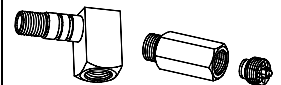

26790000 27240000

PESO TOT. RIBALTABILE 28 Ton. a 180 Bars
ÖSSZTEHERBÍRÁS 28 TONNA 180BAR MELLETT

TOTAL WEIGHT TIP-UP 28 Ton. 180 Bars
GESAMTGEWICHT KIPPANHÄNGER 20 Ton. 180 Bar

TIPO TÍPUS TYPE TYP	DISEGNO - DRAWING RAJZ - ZEICHNUNG	CORSIA - STROKE LÖKET - HUB	Ø SFILATE mm Ø TAGOK mm Ø EXTENSIONS mm Ø STUFEN mm										DIMENSIONI CILINDRO MUNKAHENGER MÉRETEI CYLINDER DIMENSIONS ZYLINDER ABMESSUNGEN						L. sfilata - L. extension Tagok hossza - L. stufen	Peso - Kg - Weight Tömeg - Kg - Gewicht		Volume olio Lt. Amount of oil Lt. Olajmennyiség - Liter Ölínhalt Lt.
			68 TON. 6,5	88 TON. 10,9	107 TON. 16,1	126 TON. 22,4	145 TON. 29,7	165 TON. 38,4	187 TON. 49,4	210 TON. 62,3	236 TON. 78,5	265 TON. 99,2	C	C ¹	F	L	L ¹	R		F	S	
1049	12965	2080	●	●	●	●	●	●	●	●	●	●	-	240	212	-	452	274	300	188	193	46
1050	12966	2270	●	●	●	●	●	●	●	●	●	●	-	240	232	-	472	290	320	195	200	50
1051	12967	2430	●	●	●	●	●	●	●	●	●	●	-	240	247	-	487	302	335	202	208	54
1052	12968	2750	●	●	●	●	●	●	●	●	●	●	-	260	272	-	532	324	380	220	230	60
1053	12969	3150	●	●	●	●	●	●	●	●	●	●	-	260	312	-	572	358	420	238	248	69
1054	12970	3450	●	●	●	●	●	●	●	●	●	●	-	260	342	-	602	384	450	254	265	76
1055	12971	3950	●	●	●	●	●	●	●	●	●	●	-	260	392	-	652	430	500	274	286	87
1056	12972	4350	●	●	●	●	●	●	●	●	●	●	-	260	432	-	692	466	540	292	303	97
1057	12973	4650	●	●	●	●	●	●	●	●	●	●	-	260	462	-	722	494	570	307	312	103

PRESSIONE MAX. DI ESERCIZIO 180 BAR - MAXIMÁLIS NYOMÁS 180 BAR
WORKING MAX. PRESSURE 180 BAR - MAX. BETRIEBSDRUCK 180 BAR

CILINDRI TELESCOPICI CON 2 SFILATE
TELESCOPIC CYLINDERS WITH 2 EXTENSIONS

TELESZKÓPOS MUNKAHENGER 2 TAGÚ
TELESKOPZYLINDER MIT 2 VERLÄNGERUNGEN

PESO TOT. RIBALTABILE 5,5 Ton. a 180 Bar

TOTAL WEIGHT TIP-UP 5,5 Ton. 180 Bar

ÖSSZTEHERBÍRÁS 5,5 TONNA 180 BAR MELLETT

GESAMTGEWICHT KIPPÄNHÄNGER 5,5 Ton. 180 Bar

TIPO TYPE TÍPUS	DISEGNO – DRAWING RAJZ - ZEICHNUNG	CORSA – STROKE LÖKET - HUB	Ø SFILATE mm Ø EXPANSIONS mm Ø TAGOK mm Ø STUFEN mm					L	L.sfilata – L. extension Tagok hossza – L. stufen	Peso – Kg – Weight		Volume oil Lt. Amount of oil Lt. Olajmennyiség - Liter Ölínhalt Lt.
			46 TON. 2,9	61 TON. 5,2	76 TON. 8,1	91 TON. 11,7	107 TON. 16,1			F	S	
3621	12015	495		●	●			377	320	17	-	2
3622	12016	595		●	●			425	370	19	-	2,3
3623	12017	695		●	●			575	420	22	-	2,7
3624	12018	795		●	●			525	470	25	-	3
3625	12019	895		●	●			578	520	27	-	3,5
3626	12020	995		●	●			630	570	29	-	3,8

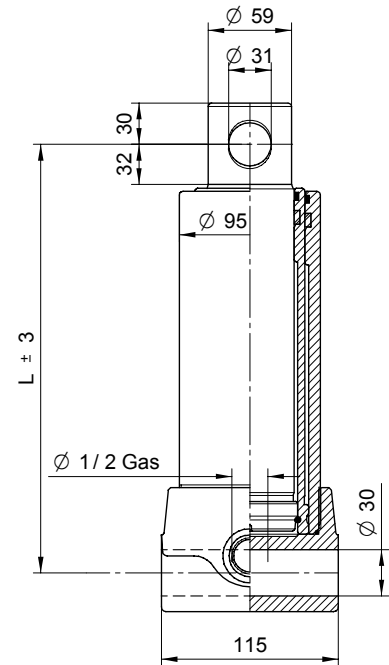

CILINDRI TELESCOPICI CON 2 SFILATE
TELESCOPIC CYLINDERS WITH 2 EXTENSIONS

TELESZKÓPOS MUNKAHENGER 2 TAGÚ
TELESKOPZYLINDER MIT 2 VERLÄNGERUNGEN

PESO TOT. RIBALTABILE 13,5 Ton. a 180 Bar

TOTAL WEIGHT TIP-UP 13,5 Ton. 180 Bar

ÖSSZTEHERBÍRÁS 13,5 TONNA 180 BAR MELLETT

GESAMTGEWICHT KIPPANHÄNGER 13,5 Ton. 180 Bar

TIPO TYPE TÍPUS	DISEGNO – DRAWING RAJZ - ZEICHNUNG	CORSA – STROKE LÖKET - HUB	Ø SFILATE mm Ø EXPANSIONS mm Ø TAGOK mm Ø STUFEN mm					L	L.sfilata – L. extension Tagok hossza – L. stufen	Peso – Kg – Weight		Volume oil Lt. Amount of oil Lt. Olajmennyiség - Liter Ölínhalt Lt.
			68 TON. 6,5	88 TON. 10,9	107 TON. 16,1	126 TON. 22,4	145 TON. 19,7			F	S	
4623	12039	695		●	●			496	420	30,5	-	5,3
4626	12042	895		●	●			596	520	36,5	-	6,8
4627	12043	1095		●	●			696	620	42,5	-	8,3
4628	12044	1195		●	●			776	700	48,5	-	9,9
4629	12045	1395		●	●			876	800	56,5	-	11,6

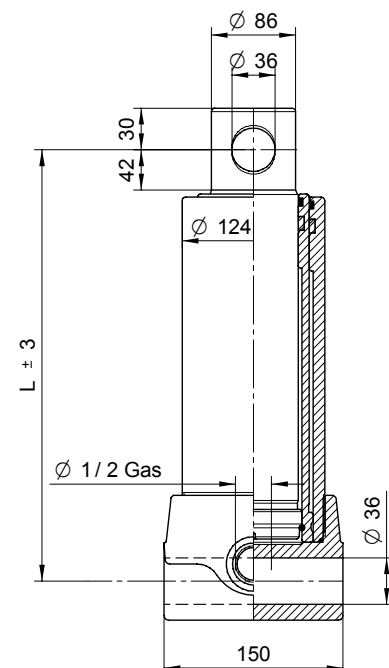

PRESSIONE MAX. DI ESERCIZIO 180 BAR - MAXIMÁLIS NYOMÁS 180 BAR
WORKING MAX. PRESSURE 180 BAR – MAX. BETRIEBSDRUCK 180 BAR

CILINDRI TELESCOPICI CON 3 SFILATE
TELESCOPIC CYLINDERS WITH 3 EXTENSIONS

TELESZKÓPOS MUNKAHENGER
TELESKOPZYLINDER MIT 3 VERLÄNGERUNGEN

PESO TOT. RIBALTABILE 5 Ton. a 180 Bar
ÖSSZTEHERBÍRÁS 5 TONNA 180 BAR MELLETT

TOTAL WEIGHT TIP-UP 5 Ton. 180 Bar
GESAMTGEWICHT KIPPÄNHÄNGER 5 Ton. 180 Bar

TIPO TYPE TÍPUS TYP	DISEGNO - DRAWING RAJZ - ZEICHNUNG	CORSA - STROKE LÖKET - HUB	Ø SFILATE mm Ø EXPANSIONS mm Ø TAGOK mm Ø STUFEN mm					L	L.sfilata - L. extension Tagok hossza - L. stufen	Peso - Kg - Weight		Volume oil Lt. Amount of oil Lt. Olajmennyiség - Liter Ölínhalt Lt.
			46 TON. 2,9	61 TON. 5,2	76 TON. 8,1	91 TON. 11,7	107 TON. 16,1			F	S	
2631	12022	500	●	●	●			292	240	13	-	1,6
2632	12023	593	●	●	●			322	270	14	-	2
2633	12024	683	●	●	●			352	300	15,5	-	2,2
2634	12025	790	●	●	●			387	335	17	-	2,5
2635	12026	893	●	●	●			422	370	18,5	-	2,8
2636	12027	1043	●	●	●			472	420	20,5	-	3,3
2637	12028	1283	●	●	●			552	500	24	-	4
2638	12029	1490	●	●	●			622	570	27,5	-	4,7

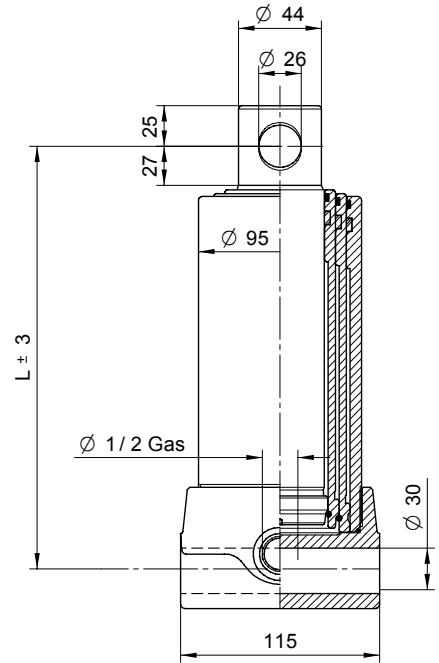

CILINDRI TELESCOPICI CON 3 SFILATE
TELESCOPIC CYLINDERS WITH 3 EXTENSIONS

TELESZKÓPOS MUNKAHENGER 3 TAGÚ
TELESKOPZYLINDER MIT 3 VERLÄNGERUNGEN

PESO TOT. RIBALTABILE 8 Ton. a 180 Bar
ÖSSZTEHERBÍRÁS 8 TONNA 180 BAR MELLETT

TOTAL WEIGHT TIP-UP 8 Ton. 180 Bar
GESAMTGEWICHT KIPPANHÄNGER 8 Ton. 180 Bar

TIPO TYPE TÍPUS TYP	DISEGNO - DRAWING RAJZ - ZEICHNUNG	CORSA - STROKE LÖKET - HUB	Ø SFILATE mm Ø EXPANSIONS mm Ø TAGOK mm Ø STUFEN mm					L	L.sfilata - L. extension Tagok hossza - L. stufen	Peso - Kg - Weight		Volume oil Lt. Amount of oil Lt. Olajmennyiség - Liter Ölínhalt Lt.
			46 TON. 2,9	61 TON. 5,2	76 TON. 8,1	91 TON. 11,7	107 TON. 16,1			F	S	
3630	12060	500		●	●	●		302	240	21	-	2,5
3631	12061	593		●	●	●		312	270	23	-	2,8
3632	12062	683		●	●	●		362	300	25	-	3,3
3633	12063	785		●	●	●		397	335	28	-	3,8
3634	12064	893		●	●	●		432	370	30	-	4,2
3635	12065	1043		●	●	●		482	420	34	-	5
3636	12066	1283		●	●	●		562	500	39	-	6
3637	12067	1493		●	●	●		632	570	43	-	7

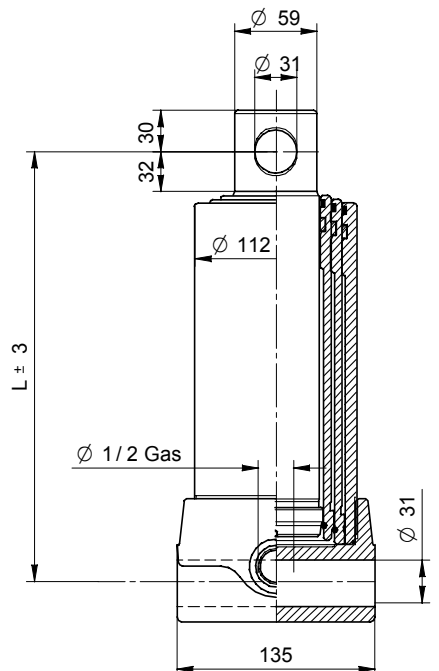

PRESSIONE MAX. DI ESERCIZIO 180 BAR - MAXIMÁLIS NYOMÁS 180 BAR
WORKING MAX. PRESSURE 180 BAR - MAX. BETRIEBSDRUCK 180 BAR

CILINDRI TELESCOPICI CON 3 SFILATE
TELESCOPIC CYLINDERS WITH 3 EXTENSIONS

TELESZKÓPOS MUNKAHENGER 3 TAGÚ
TELESKOPZYLINDER MIT 3 VERLÄNGERUNGEN

PESO TOT. RIBALTABILE 11 Ton. a 180 Bar

TOTAL WEIGHT TIP-UP 11 Ton. 180 Bar

ÖSSZTEHERBÍRÁS 11 TONNA 180 BAR MELLETT

GESAMTGEWICHT KIPPÄNHÄNGER 11 Ton. 180 Bar

TIPO TYPE TÍPUS	DISEGNO - DRAWING RAJZ - ZEICHNUNG	CORSA - STROKE LÖKET - HUB	Ø SFILATE mm Ø EXPANSIONS mm Ø TAGOK mm Ø STUFEN mm					L	L.sfilata - L. extension Tagok hossza - L.stufen	Peso - Kg - Weight		Volume oil Lt. Amount of oil Lt. Olajmennyiség - Liter Ölínhalt Lt.
			68 TON. 6,5	88 TON. 10,9	107 TON. 16,1	126 TON. 22,4	145 TON. 19,7			F	S	
4631	12046	743	●	●	●			398	320	33	-	4,7
4632	12047	790	●	●	●			413	335	34	-	5
4633	12048	893	●	●	●			448	370	36	-	5,7
4634	12049	1043	●	●	●			498	420	40	-	6,6
4635	12050	1283	●	●	●			578	500	47	-	8,2
4637	12052	1493	●	●	●			648	570	53	-	9,4
4630	12055	2093	●	●	●			878	800	70	-	13

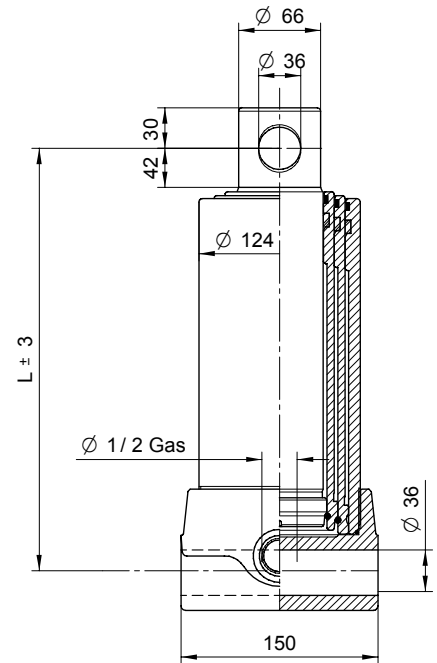

CILINDRI TELESCOPICI CON 3 SFILATE
TELESCOPIC CYLINDERS WITH 3 EXTENSIONS

TELESZKÓPOS MUNKAHENGER 3 TAGÚ
TELESKOPZYLINDER MIT 3 VERLÄNGERUNGEN

PESO TOT. RIBALTABILE 16,5 Ton. a 180 Bar

TOTAL WEIGHT TIP-UP 16,5 Ton. 180 Bar

ÖSSZTEHERBÍRÁS 1 ,5 TONNA 180 BAR MELLETT

GESAMTGEWICHT KIPPANHÄNGER 16,5 Ton. 180 Bar

TIPO TYPE TÍPUS	DISEGNO - DRAWING RAJZ - ZEICHNUNG	CORSA - STROKE LÖKET - HUB	Ø SFILATE mm Ø EXPANSIONS mm Ø TAGOK mm Ø STUFEN mm					L	L.sfilata - L. extension Tagok hossza - L.stufen	Peso - Kg - Weight		Volume oil Lt. Amount of oil Lt. Olajmennyiség - Liter Ölínhalt Lt.
			68 TON. 6,5	88 TON. 10,9	107 TON. 16,1	126 TON. 22,4	145 TON. 19,7			F	S	
4636	12051	1273		●	●	●		588	500	56	-	12
4638	12053	1483		●	●	●		658	570	62	-	13,8
4639	12054	2093		●	●	●		888	800	82	-	20

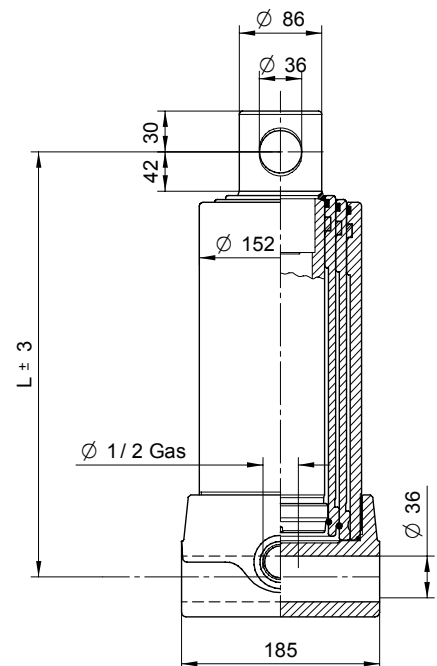

PRESSIONE MAX. DI ESERCIZIO 180 BAR - MAXIMÁLIS NYOMÁS 180 BAR
WORKING MAX. PRESSURE 180 BAR - MAX. BETRIEBSDRUCK 180 BAR

CILINDRI TELESCOPICI CON 4 SFILATE
TELESCOPIC CYLINDERS WITH 4 EXTENSIONS

TELESZKÓPOS MUNKAHENGER 4 TAGÚ
TELESKOPZYLINDER MIT 4 VERLÄNGERUNGEN

PESO TOT. RIBALTABILE 7 Ton. a 180 Bar

TOTAL WEIGHT TIP-UP 7 Ton. 180 Bar

ÖSSZTEHERBÍRÁS TONNA 180 BAR MELLETT

GESAMTGEWICHT KIPPÄNHÄNGER 7 Ton. 180 Bar

TIPO TYPE TÍPUS TYP	DISEGNO - DRAWING RAJZ - ZEICHNUNG	CORSA - STROKE LÖKET - HUB	Ø SFILATE mm Ø EXPANSIONS mm Ø TAGOK mm Ø STUFEN mm					L	L.sfilata - L. extension Tagok hossza - L.stufen	Peso - Kg - Weight		Volume olio Lt. Amount of oil Lt. Olajmennyiség - Liter Ölínhalt Lt.
			46 TON. 2,9	61 TON. 5,2	76 TON. 8,1	91 TON. 11,7	107 TON. 16,1			F	S	
3661	12080	590	●	●	●	●		280	220	19	-	2,4
3662	12081	673	●	●	●	●		300	240	19,5	-	2,7
3663	12082	790	●	●	●	●		330	270	20,5	-	3,2
3664	12083	910	●	●	●	●		360	300	23,5	-	3,6
3665	12084	1060	●	●	●	●		395	335	25,5	-	4,3
3666	12085	1190	●	●	●	●		430	370	27,5	-	4,7
3667	12086	1390	●	●	●	●		480	420	31	-	6
3668	12087	1710	●	●	●	●		560	500	35,5	-	6,7
3669	12088	1990	●	●	●	●		630	570	39	-	7,9

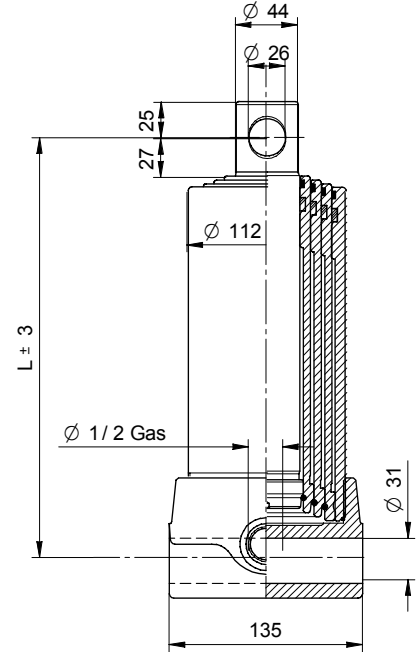

CILINDRI TELESCOPICI CON 4 SFILATE
TELESCOPIC CYLINDERS WITH 4 EXTENSIONS

TELESZKÓPOS MUNKAHENGER 4 TAGÚ
TELESKOPZYLINDER MIT 4 VERLÄNGERUNGEN

PESO TOT. RIBALTABILE 10 Ton. a 180 Bar

TOTAL WEIGHT TIP-UP 10 Ton. 180 Bar

ÖSSZTEHERBÍRÁS 10 TONNA 180 BAR MELLETT

GESAMTGEWICHT KIPPANHÄNGER 10 Ton. 180 Bar

TIPO TYPE TÍPUS TYP	DISEGNO - DRAWING RAJZ - ZEICHNUNG	CORSA - STROKE LÖKET - HUB	Ø SFILATE mm Ø EXPANSIONS mm Ø TAGOK mm Ø STUFEN mm					L	L.sfilata - L. extension Tagok hossza - L.stufen	Peso - Kg - Weight		Volume olio Lt. Amount of oil Lt. Olajmennyiség - Liter Ölínhalt Lt.
			46 TON. 2,9	61 TON. 5,2	76 TON. 8,1	91 TON. 11,7	107 TON. 16,1			F	S	
3641	11999	670		●	●	●	●	313	240	25	-	4
3642	12000	830		●	●	●	●	353	280	28,5	-	5
3643	12001	950		●	●	●	●	383	310	30	-	5,6
3644	12002	1050		●	●	●	●	408	335	32	-	6,2
3645	12003	1190		●	●	●	●	443	370	34,5	-	7
3646	12004	1290		●	●	●	●	468	395	37,5	-	7,5
3647	12005	1510		●	●	●	●	523	450	41,5	-	8,8
3648	12006	1710		●	●	●	●	573	500	45	-	10
3649	12007	1990		●	●	●	●	640	570	49,5	-	11

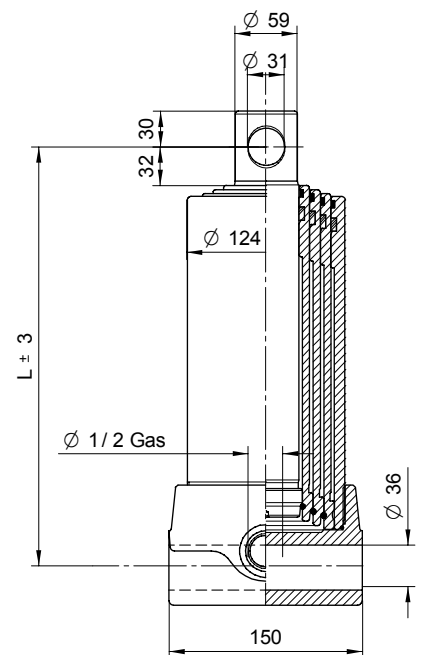

PRESSIONE MAX. DI ESERCIZIO 180 BAR - MAXIMÁLIS NYOMÁS 180 BAR
WORKING MAX. PRESSURE 180 BAR - MAX. BETRIEBSDRUCK 180 BAR

CILINDRI TELESCOPICI CON 4 SFILATE
TELESCOPIC CYLINDERS WITH 4 EXTENSIONS

TELESZKÓPOS MUNKAHENGER 4 TAGÚ
TELESKOPZYLINDER MIT 4 VERLÄNGERUNGEN

PESO TOT. RIBALTABILE 14 Ton. a 180 Bar

TOTAL WEIGHT TIP-UP 14 Ton. 180 Bar

ÖSSZTEHERBÍRÁS 1 TONNA 180 BAR MELLETT

GESAMTGEWICHT KIPPÄNHANGER 14 Ton. 180 Bar

TIPO TYPE TÍPUS	DISEGNO – DRAWING RAJZ - ZEICHNUNG	CORSO – STROKE LÖKET - HUB	Ø SFILATE mm Ø EXPANSIONS mm Ø TAGOK mm Ø STUFEN mm					L	L.sfilata – L. extension Tagok hossza – L. stufen	Peso – Kg – Weight Tömeg – Kg - Gewicht		Volume oilo Lt. Amount of oil Lt. Olajmennyiség - Liter Ölínhalt Lt.
			68 TON. 6,5	88 TON. 10,9	107 TON. 16,1	126 TON. 22,4	145 TON. 29,7			F	S	
4640	12070	1980	●	●	●	●		663	570	76,5	-	15,6
4641	12071	1040	●	●	●	●		426	335	49	-	8,3
4642	12072	1220	●	●	●	●		473	380	54,5	-	9,7
4643	12073	1500	●	●	●	●		543	450	62,5	-	12
4644	12074	1700	●	●	●	●		593	500	68,5	-	13,5

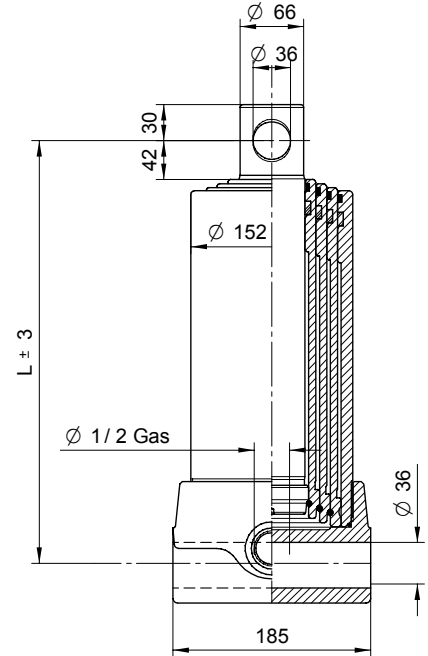

PRESSIONE MAX. DI ESERCIZIO 180 BAR - MAXIMÁLIS NYOMÁS 180 BAR
WORKING MAX. PRESSURE 180 BAR – MAX. BETRIEBSDRUCK 180 BAR

CILINDRI TELESCOPICI CON 2 SFILATE
TELESCOPIC CYLINDERS WITH 2 EXTENSIONS

TELESZKÓPOS MUNKAHENGER 2 TAGÚ
TELESKOPZYLINDER MIT 2 VERLÄNGERUNGEN

PESO TOT. RIBALTABILE 3,5 Ton. a 180 Bar
ÖSSZTEHERBÍRÁS 3,5 TONNA 180 BAR MELLETT

TOTAL WEIGHT TIP-UP 3,5 Ton. 180 Bar
GESAMTGEWICHT KIPPÄNHÄNGER 3,5 Ton. 180 Bar

TIPO TYPE TÍPUS	DISEGNO - DRAWING RAJZ - ZEICHNUNG	CORSA - STROKE LÖKET - HUB	Ø SFILATE mm Ø EXPANSIONS mm Ø TAGOK mm Ø STUFEN mm					L ¹	L.sfilata - L. extension Tagok hossza - L.stufen	Peso - Kg - Weight		Volume olio Lt. Amount of oil Lt. Olajmennyiség - Liter Ölínhalt Lt.
			46 TON. 2,9	61 TON. 5,2	76 TON. 8,1	91 TON. 11,7	107 TON. 16,1			F	S	
2720	12170	455	●	●				442	300	-	16,9	1,1
2721	12171	525	●	●				477	335	-	17,4	1,3
2722	12172	595	●	●				514	370	-	18,4	1,5
2723	12173	695	●	●				564	420	-	20,4	1,7
2724	12174	795	●	●				612	470	-	21,9	2
2725	12175	895	●	●				662	520	-	23,9	2,2
2726	12176	995	●	●				712	570	-	25,9	2,4

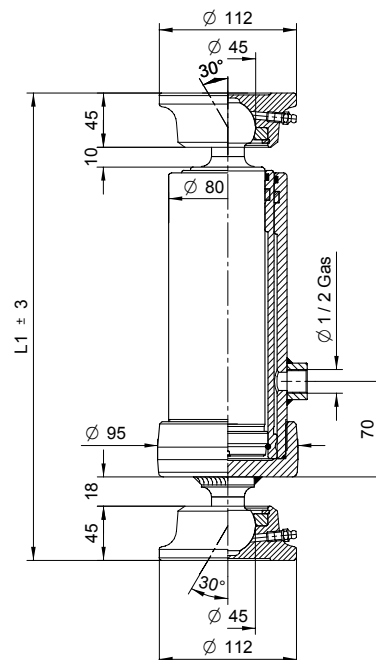

CILINDRI TELESCOPICI CON 2 SFILATE
TELESCOPIC CYLINDERS WITH 2 EXTENSIONS

TELESZKÓPOS MUNKAHENGER 2 TAGÚ
TELESKOPZYLINDER MIT 2 VERLÄNGERUNGEN

PESO TOT. RIBALTABILE 5,5 Ton. a 180 Bar
ÖSSZTEHERBÍRÁS 5,5 TONNA 180 BAR MELLETT

TOTAL WEIGHT TIP-UP 5,5 Ton. 180 Bar
GESAMTGEWICHT KIPPANHÄNGER 5,5 Ton. 180 Bar

TIPO TYPE TÍPUS	DISEGNO - DRAWING RAJZ - ZEICHNUNG	CORSA - STROKE LÖKET - HUB	Ø SFILATE mm Ø EXPANSIONS mm Ø TAGOK mm Ø STUFEN mm					L ¹	L.sfilata - L. extension Tagok hossza - L.stufen	Peso - Kg - Weight		Volume olio Lt. Amount of oil Lt. Olajmennyiség - Liter Ölínhalt Lt.
			46 TON. 2,9	61 TON. 5,2	76 TON. 8,1	91 TON. 11,7	107 TON. 16,1			F	S	
3721	12195	495		●	●			490	320	-	22	2
3722	12196	595		●	●			538	370	-	24	2,3
3723	12197	695		●	●			588	420	-	27	2,7
3724	12198	795		●	●			738	470	-	30	3
3725	12199	895		●	●			691	520	-	32	3,5
3726	12200	995		●	●			743	570	-	34	3,8

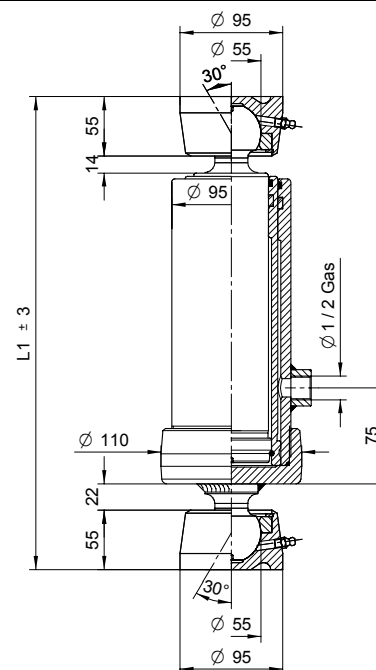

PRESSIONE MAX. DI ESERCIZIO 180 BAR - MAXIMÁLIS NYOMÁS 180 BAR
WORKING MAX. PRESSURE 180 BAR - MAX. BETRIEBSDRUCK 180 BAR

CILINDRI TELESCOPICI CON 3 SFILATE
TELESCOPIC CYLINDERS WITH 3 EXTENSIONS

TELESZKÓPOS MUNKAHENGER 3 TAGÚ
TELESKOPZYLINDER MIT 3 VERLÄNGERUNGEN

PESO TOT. RIBALTABILE 5 Ton. a 180 Bar
ÖSSZTEHERBÍRÁS 5 TONNA 180 BAR MELLETT

TOTAL WEIGHT TIP-UP 5 Ton. 180 Bar
GESAMTGEWICHT KIPPÄNHÄNGER 5 Ton. 180 Bar

TIPO TYPE TÍPUS	DISEGNO - DRAWING RAJZ - ZEICHNUNG	CORSA - STROKE LÖKET - HUB	Ø SFILATE mm Ø EXPANSIONS mm Ø TAGOK mm Ø STUFEN mm					L ¹	L.sfilata - L. extension Tagok hossza - L.stufen	Peso - Kg - Weight		Volume oil Lt. Amount of oil Lt. Olajmennyiség - Liter Ölínhalt Lt.
			46 TON. 2,9	61 TON. 5,2	76 TON. 8,1	91 TON. 11,7	107 TON. 16,1			F	S	
2731	12181	500	●	●	●			385	240	-	17	1,6
2732	12182	593	●	●	●			415	270	-	18	2
2733	12183	683	●	●	●			445	300	-	19,5	2,2
2734	12184	790	●	●	●			480	335	-	21	2,5
2735	12185	893	●	●	●			515	370	-	22,5	2,8
2736	12186	1043	●	●	●			565	420	-	24,5	3,3
2737	12187	1283	●	●	●			645	500	-	28	4
2738	12188	1490	●	●	●			715	570	-	31,5	4,7

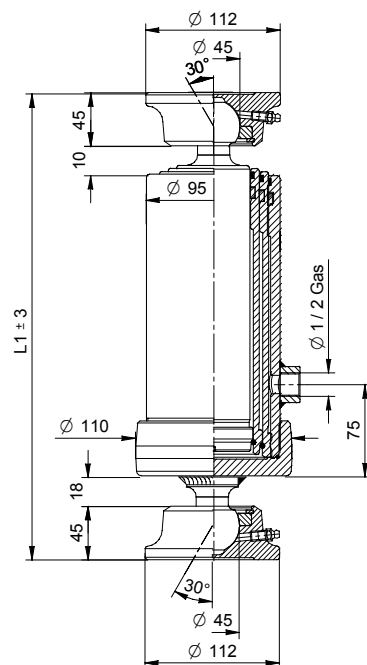

CILINDRI TELESCOPICI CON 3 SFILATE
TELESCOPIC CYLINDERS WITH 3 EXTENSIONS

TELESZKÓPOS MUNKAHENGER 3 TAGÚ
TELESKOPZYLINDER MIT 3 VERLÄNGERUNGEN

PESO TOT. RIBALTABILE 7,5 Ton. a 180 Bar
ÖSSZTEHERBÍRÁS 7,5 TONNA 180 BAR MELLETT

TOTAL WEIGHT TIP-UP 7,5 Ton. 180 Bar
GESAMTGEWICHT KIPPÄNHÄNGER 7,5 Ton. 180 Bar

TIPO TYPE TÍPUS	DISEGNO - DRAWING RAJZ - ZEICHNUNG	CORSA - STROKE LÖKET - HUB	Ø SFILATE mm Ø EXPANSIONS mm Ø TAGOK mm Ø STUFEN mm					L ¹	L.sfilata - L. extension Tagok hossza - L.stufen	Peso - Kg - Weight		Volume oil Lt. Amount of oil Lt. Olajmennyiség - Liter Ölínhalt Lt.
			46 TON. 2,9	61 TON. 5,2	76 TON. 8,1	91 TON. 11,7	107 TON. 16,1			F	S	
3730	12204	500		●	●	●		415	240	-	24	2,5
3731	12205	593		●	●	●		445	270	-	26	2,8
3732	12206	683		●	●	●		475	300	-	28	3,3
3733	12207	790		●	●	●		510	335	-	30	3,8
3734	12208	893		●	●	●		545	370	-	33	4,2
3735	12209	1043		●	●	●		595	420	-	37	5
3736	12210	1283		●	●	●		675	500	-	42	6
3737	12211	1493		●	●	●		745	570	-	46	7

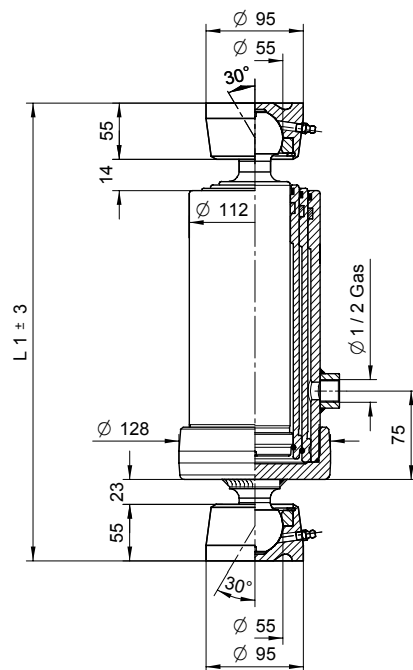

PRESSIONE MAX. DI ESERCIZIO 180 BAR - MAXIMÁLIS NYOMÁS 180 BAR
WORKING MAX. PRESSURE 180 BAR - MAX. BETRIEBSDRUCK 180 BAR

ALUL-FELÜL GÖMBÖS MUNKAHENGEREK



CILINDRI TELESCOPICI CON 3 SFILATE
TELESCOPIC CYLINDERS WITH 3 EXTENSIONS

TELESZKÓPOS MUNKAHENGER 3 TAGÚ
TELESKOPZYLINDER MIT 3 VERLÄNGERUNGEN

PESO TOT. RIBALTABILE 11 Ton. a 180 Bar

TOTAL WEIGHT TIP-UP 11 Ton. 180 Bar

ÖSSZTEHERBÍRÁS 11 TONNA 180 BAR MELLETT

GESAMTGEWICHT KIPPÄNHÄNGER 11 Ton. 180 Bar

TIPO TYPE TÍPUS	DISEGNO - DRAWING RAJZ - ZEICHNUNG	CORSA - STROKE LÖKET - HUB	Ø SFILATE mm Ø EXPANSIONS mm Ø TAGOK mm Ø STUFEN mm					L ¹	L.sfilata - L. extension Tagok hossza - L.stufen	Peso - Kg - Weight		Volume oil Lt. Amount of oil Lt. Olajmennyiség - Liter Ölínhalt Lt.
			68 TON. 6,5	88 TON. 10,9	107 TON. 16,1	126 TON. 22,4	145 TON. 19,7			F	S	
4731	12290	743	●	●	●			505	320	-	37	4,7
4732	12291	790	●	●	●			520	335	-	38	5
4733	12292	893	●	●	●			555	370	-	40	5,7
4734	12293	1043	●	●	●			605	420	-	44	6,6
4735	12294	1283	●	●	●			685	500	-	51	8,2
4737	12296	1493	●	●	●			755	570	-	57	9,4

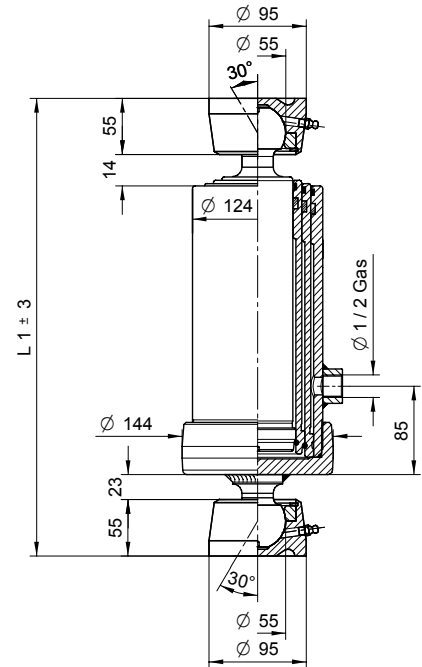

CILINDRI TELESCOPICI CON 3 SFILATE
TELESCOPIC CYLINDERS WITH 3 EXTENSIONS

TELESZKÓPOS MUNKAHENGER 3 TAGÚ
TELESKOPZYLINDER MIT 3 VERLÄNGERUNGEN

PESO TOT. RIBALTABILE 16,5 Ton. a 180 Bar

TOTAL WEIGHT TIP-UP 16,5 Ton. 180 Bar

ÖSSZTEHERBÍRÁS 1 ,5 TONNA 180 BAR MELLETT

GESAMTGEWICHT KIPPANHÄNGER 16,5 Ton. 180 Bar

TIPO TYPE TÍPUS	DISEGNO - DRAWING RAJZ - ZEICHNUNG	CORSA - STROKE LÖKET - HUB	Ø SFILATE mm Ø EXPANSIONS mm Ø TAGOK mm Ø STUFEN mm					L ¹	L.sfilata - L. extension Tagok hossza - L.stufen	Peso - Kg - Weight		Volume oil Lt. Amount of oil Lt. Olajmennyiség - Liter Ölínhalt Lt.
			68 TON. 6,5	88 TON. 10,9	107 TON. 16,1	126 TON. 22,4	145 TON. 19,7			F	S	
4736	12295	1273		●	●	●		698	500	-	59	12
4738	12297	1483		●	●	●		768	570	-	65	13,8
4739	12298	2093		●	●	●		998	800	-	85	20

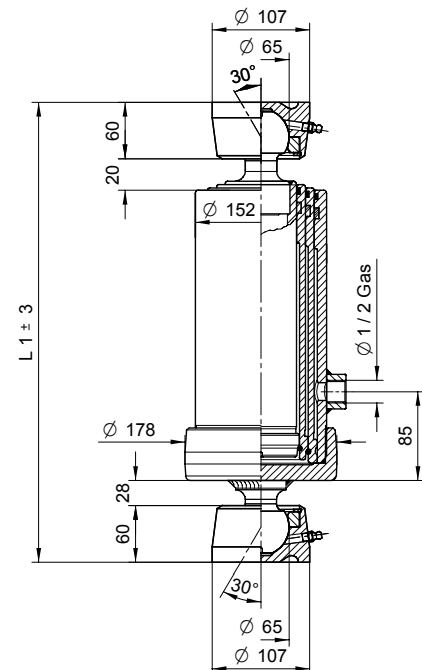

PRESSIONE MAX. DI ESERCIZIO 180 BAR - MAXIMÁLIS NYOMÁS 180 BAR
WORKING MAX. PRESSURE 180 BAR - MAX. BETRIEBSDRUCK 180 BAR

CILINDRI TELESCOPICI CON 2 SFILATE
TELESCOPIC CYLINDERS WITH 2 EXTENSIONS

TELESZKÓPOS MUNKAHENGER 2 TAGÚ
TELESKOPZYLINDER MIT 2 VERLÄNGERUNGEN

PESO TOT. RIBALTABILE 3,5 Ton. a 180 Bar
ÖSSZTEHERBÍRÁS 3,5 TONNA 180 BAR MELLETT

TOTAL WEIGHT TIP-UP 3,5 Ton. 180 Bar
GESAMTGEWICHT KIPPÄNHÄNGER 3,5 Ton. 180 Bar

TIPO TYPE TÍPUS	DISEGNO - DRAWING RAJZ - ZEICHNUNG	CORSA - STROKE LÖKET - HUB	Ø SFILATE mm Ø EXPANSIONS mm Ø TAGOK mm Ø STUFEN mm					L	L.sfilata - L. extension Tagok hossza - L.stufen	Peso - Kg - Weight		Volume olio Lt. Amount of oil Lt. Olajmennyiség - Liter Ölínhalt Lt.
			46 TON. 2,9	61 TON. 5,2	76 TON. 8,1	91 TON. 11,7	107 TON. 16,1			F	S	
2520	10131	455	●	●				340	300	14	15,5	1,1
2521	10133	525	●	●				375	335	14,5	16	1,3
2522	10135	595	●	●				410	370	15,5	17	1,5
2523	10137	695	●	●				460	420	17,5	19	1,7
2524	3398	795	●	●				510	470	19	20,5	2
2525	3399	895	●	●				560	520	21	22,5	2,2
2526	10143	995	●	●				610	570	23	24,5	2,4

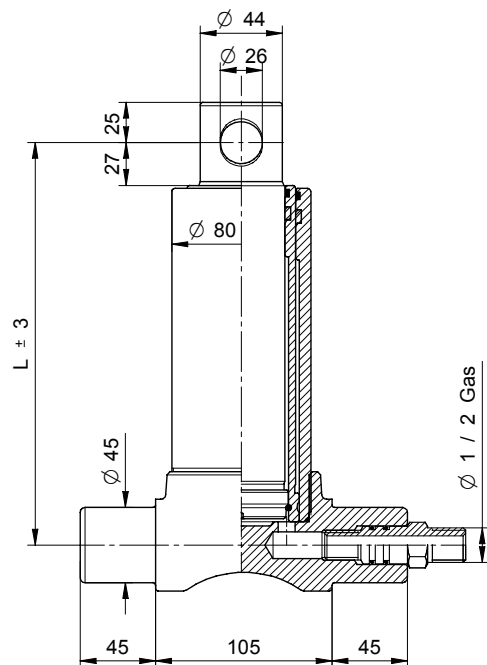

CILINDRI TELESCOPICI CON 2 SFILATE
TELESCOPIC CYLINDERS WITH 2 EXTENSIONS

TELESZKÓPOS MUNKAHENGER 2 TAGÚ
TELESKOPZYLINDER MIT 2 VERLÄNGERUNGEN

PESO TOT. RIBALTABILE 5,5 Ton. a 180 Bar
ÖSSZTEHERBÍRÁS 5,5 TONNA 180 BAR MELLETT

TOTAL WEIGHT TIP-UP 5,5 Ton. 180 Bar
GESAMTGEWICHT KIPPÄNHÄNGER 5,5 Ton. 180 Bar

TIPO TYPE TÍPUS	DISEGNO - DRAWING RAJZ - ZEICHNUNG	CORSA - STROKE LÖKET - HUB	Ø SFILATE mm Ø EXPANSIONS mm Ø TAGOK mm Ø STUFEN mm					L	L.sfilata - L. extension Tagok hossza - L.stufen	Peso - Kg - Weight		Volume olio Lt. Amount of oil Lt. Olajmennyiség - Liter Ölínhalt Lt.
			46 TON. 2,9	61 TON. 5,2	76 TON. 8,1	91 TON. 11,7	107 TON. 16,1			F	S	
3521	3405	495		●	●			368	335	18	20	2
3522	3406	595		●	●			418	370	20	22	2,3
3523	3407	695		●	●			468	420	23	25	2,7
3524	3408	795		●	●			518	470	26	28	3
3525	3409	895		●	●			568	520	28	30	3,5
3526	10154	995		●	●			618	570	30	32	3,8

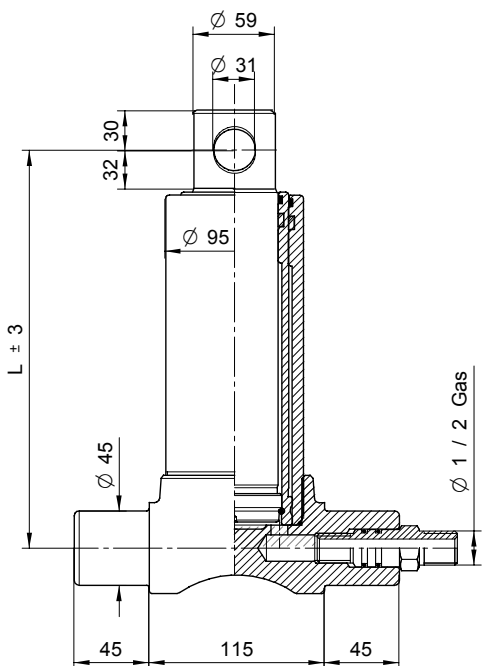

PRESSIONE MAX. DI ESERCIZIO 180 BAR - MAXIMÁLIS NYOMÁS 180 BAR
WORKING MAX. PRESSURE 180 BAR - MAX. BETRIEBSDRUCK 180 BAR

CILINDRI TELESCOPICI CON 2 SFILATE
TELESCOPIC CYLINDERS WITH 2 EXTENSIONS

TELESZKÓPOS MUNKAHENGER 2 TAGÚ
TELESKOPZYLINDER MIT 2 VERLÄNGERUNGEN

PESO TOT. RIBALTABILE 8,5 Ton. a 180 Bar
ÖSSZTEHERBÍRÁS 8,5 TONNA 180 BAR MELLETT

TOTAL WEIGHT TIP-UP 8,5 Ton. 180 Bar
GESAMTGEWICHT KIPPÄNHÄNGER 8,5 Ton. 180 Bar

TIPO TYPE TÍPUS	DISEGNO - DRAWING RAJZ - ZEICHNUNG	CORSA - STROKE LÖKET - HUB	Ø SFILATE mm Ø EXPANSIONS mm Ø TAGOK mm Ø STUFEN mm					L	L.sfilata - L. extension Tagok hossza - L.stufen	Peso - Kg - Weight		Volume olio Lt. Amount of oil Lt. Olajmennyiség - Liter Ölínhalt Lt.
			68 TON. 6,5	88 TON. 10,9	107 TON. 16,1	126 TON. 22,4	145 TON. 29,7			F	S	
										F	S	
4521	3433	595	●	●				430	370	27	29	3
4522	3434	695	●	●				480	420	30	32	3,5
4524	3436	795	●	●				530	470	33	35	4
4525	3437	895	●	●				580	520	36	38	4,5

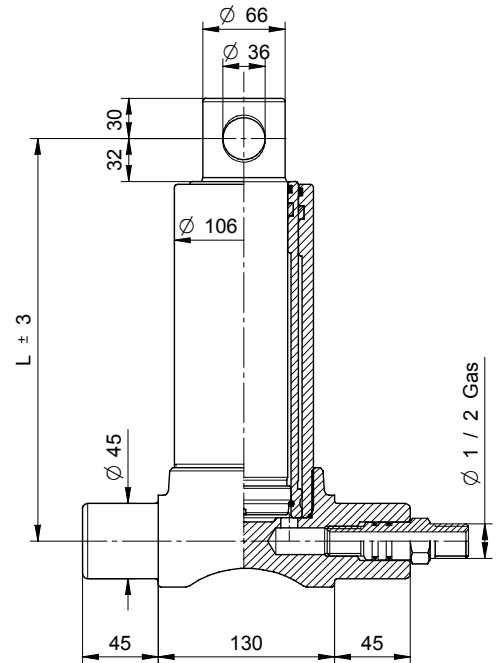

CILINDRI TELESCOPICI CON 2 SFILATE
TELESCOPIC CYLINDERS WITH 2 EXTENSIONS

TELESZKÓPOS MUNKAHENGER 2 TAGÚ
TELESKOPZYLINDER MIT 2 VERLÄNGERUNGEN

PESO TOT. RIBALTABILE 13,5 Ton. a 180 Bar
ÖSSZTEHERBÍRÁS 13,5 TONNA 180 BAR MELLETT

TOTAL WEIGHT TIP-UP 13,5 Ton. 180 Bar
GESAMTGEWICHT KIPPANHÄNGER 13,5 Ton. 180 Bar

TIPO TYPE TÍPUS	DISEGNO - DRAWING RAJZ - ZEICHNUNG	CORSA - STROKE LÖKET - HUB	Ø SFILATE mm Ø EXPANSIONS mm Ø TAGOK mm Ø STUFEN mm					L	L.sfilata - L. extension Tagok hossza - L.stufen	Peso - Kg - Weight		Volume olio Lt. Amount of oil Lt. Olajmennyiség - Liter Ölínhalt Lt.
			68 TON. 6,5	88 TON. 10,9	107 TON. 16,1	126 TON. 22,4	145 TON. 29,7			F	S	
										F	S	
4523	3435	695		●	●			480	420	30,5	33	5,3
4526	3438	895		●	●			580	520	36,5	39	6,8
4527	3439	1095		●	●			680	620	42,5	45	8,3

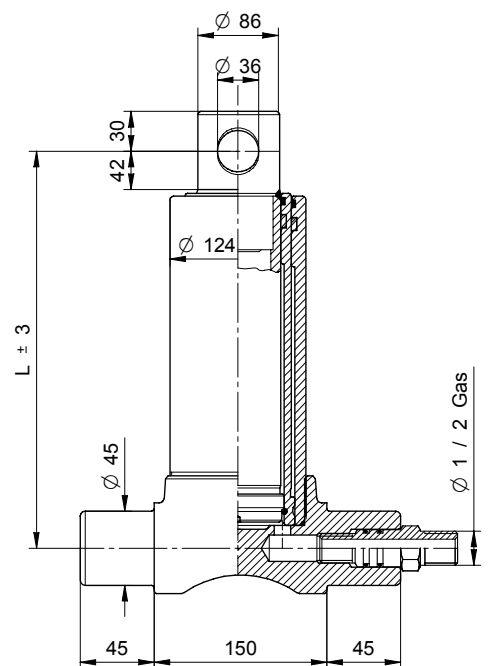

PRESSIONE MAX. DI ESERCIZIO 180 BAR - MAXIMÁLIS NYOMÁS 180 BAR
WORKING MAX. PRESSURE 180 BAR - MAX. BETRIEBSDRUCK 180 BAR

CILINDRI TELESCOPICI CON 3 SFILATE
TELESCOPIC CYLINDERS WITH 3 EXTENSIONS

TELESZKÓPOS MUNKAHENGER 3 TAGÚ
TELESKOPZYLINDER MIT 3 VERLÄNGERUNGEN

PESO TOT. RIBALTABILE 5 Ton. a 180 Bar
ÖSSZTEHERBÍRÁS 5 TONNA 180 BAR MELLETT

TOTAL WEIGHT TIP-UP 5 Ton. 180 Bar
GESAMTGEWICHT KIPPÄNHÄNGER 5 Ton. 180 Bar

TIPO TYPE TÍPUS	DISEGNO - DRAWING RAJZ - ZEICHNUNG	CORSA - STROKE LÖKET - HUB	Ø SFILATE mm Ø EXPANSIONS mm Ø TAGOK mm Ø STUFEN mm					L	L.sfilata - L. extension Tagok hossza - L. stufen	Peso - Kg - Weight		Volume oil Lt. Amount of oil Lt. Olajmennyiség - Liter Ölínhalt Lt.
			46 TON. 2,9	61 TON. 5,2	76 TON. 8,1	91 TON. 11,7	107 TON. 16,1			F	S	
2531	3400	500	●	●	●			282	240	14	15,5	1,6
2532	3401	593	●	●	●			312	270	15	16,5	2
2533	3402	683	●	●	●			342	300	16,5	18	2,2
2534	3403	790	●	●	●			377	335	18	19,5	2,5
2535	3404	893	●	●	●			412	370	19,5	21	2,8
2536	10149	1043	●	●	●			462	420	21,5	23	3,3
2537	10151	1283	●	●	●			542	500	25	26,5	4
2538	10153	1490	●	●	●			612	570	28,5	30	4,7

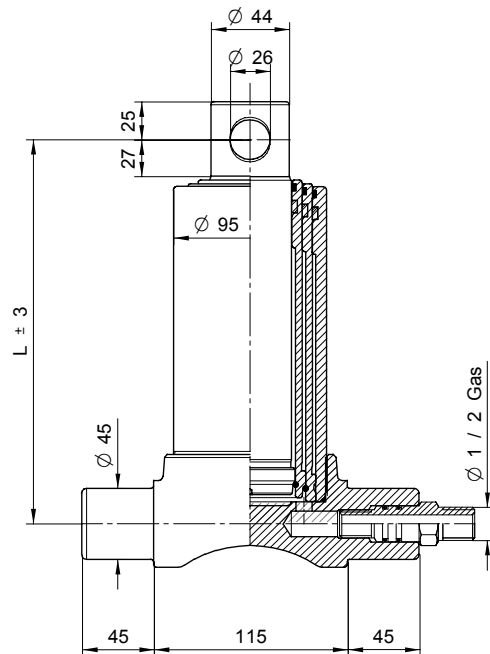

CILINDRI TELESCOPICI CON 3 SFILATE
TELESCOPIC CYLINDERS WITH 3 EXTENSIONS

TELESZKÓPOS MUNKAHENGER 3 TAGÚ
TELESKOPZYLINDER MIT 3 VERLÄNGERUNGEN

PESO TOT. RIBALTABILE 7,5 Ton. a 180 Bar
ÖSSZTEHERBÍRÁS 7,5 TONNA 180 BAR MELLETT

TOTAL WEIGHT TIP-UP 7,5 Ton. 180 Bar
GESAMTGEWICHT KIPPANHÄNGER 7,5 Ton. 180 Bar

TIPO TYPE TÍPUS	DISEGNO - DRAWING RAJZ - ZEICHNUNG	CORSA - STROKE LÖKET - HUB	Ø SFILATE mm Ø EXPANSIONS mm Ø TAGOK mm Ø STUFEN mm					L	L.sfilata - L. extension Tagok hossza - L. stufen	Peso - Kg - Weight		Volume oil Lt. Amount of oil Lt. Olajmennyiség - Liter Ölínhalt Lt.
			46 TON. 2,9	61 TON. 5,2	76 TON. 8,1	91 TON. 11,7	107 TON. 16,1			F	S	
3530	3410	500		●	●	●		292	240	20	22	2,5
3531	3411	593		●	●	●		322	270	22	24	2,8
3532	3412	683		●	●	●		352	300	24	26	3,3
3533	3413	790		●	●	●		387	335	27	29	3,8
3534	3414	893		●	●	●		422	370	29	31	4,2
3535	3415	1043		●	●	●		472	420	33	35	5
3536	3416	1283		●	●	●		552	500	38	40	6
3537	10155	1493		●	●	●		622	570	42	44	7

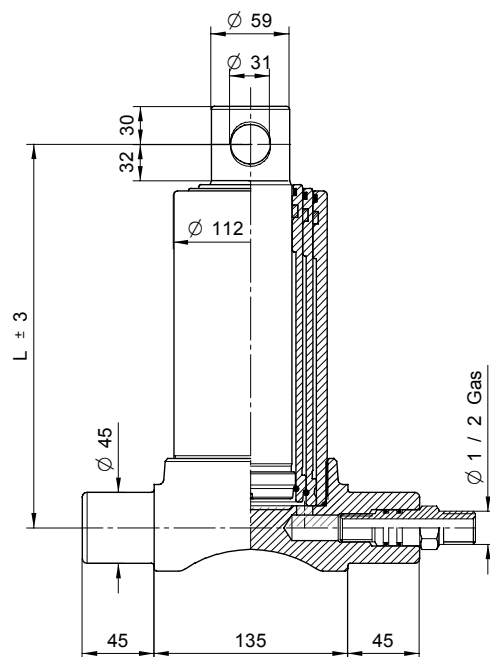

PRESSIONE MAX. DI ESERCIZIO 180 BAR - MAXIMÁLIS NYOMÁS 180 BAR
WORKING MAX. PRESSURE 180 BAR - MAX. BETRIEBSDRUCK 180 BAR

ALSÓ CSAPOS MUNKAHENGEREK



KKT

CILINDRI TELESCOPICI CON 3 SFILATE
TELESCOPIC CYLINDERS WITH 3 EXTENSIONS

TELESZKÓPOS MUNKAHENGER 3 TAGÚ
TELESKOPZYLINDER MIT 3 VERLÄNGERUNGEN

PESO TOT. RIBALTABILE 11 Ton. a 180 Bar

TOTAL WEIGHT TIP-UP 11 Ton. 180 Bar

ÖSSZTEHERBÍRÁS 11 TONNA 180 BAR MELLETT

GESAMTGEWICHT KIPPÄNHÄNGER 11 Ton. 180 Bar

TIPO TYPE TÍPUS	DISEGNO - DRAWING RAJZ - ZEICHNUNG	CORSA - STROKE LÖKET - HUB	Ø SFILATE mm Ø EXPANSIONS mm Ø TAGOK mm Ø STUFEN mm					L	L.sfilata - L. extension Tagok hossza - L.stufen	Peso - Kg - Weight		Volume oil Lt. Amount of oil Lt. Olajmennyiség - Liter Ölínhalt Lt.
			68 TON. 6,5	88 TON. 10,9	107 TON. 16,1	126 TON. 22,4	145 TON. 19,7			F	S	
4531	3441	743	●	●	●			382	320	33	35	4,7
4532	3442	790	●	●	●			397	335	34	36	5
4533	3443	893	●	●	●			432	370	36	38	5,7
4534	3444	1043	●	●	●			482	420	40	42	6,6
4535	3445	1283	●	●	●			562	500	47	49	8,2
4537	3447	1493	●	●	●			632	570	53	55	9,4

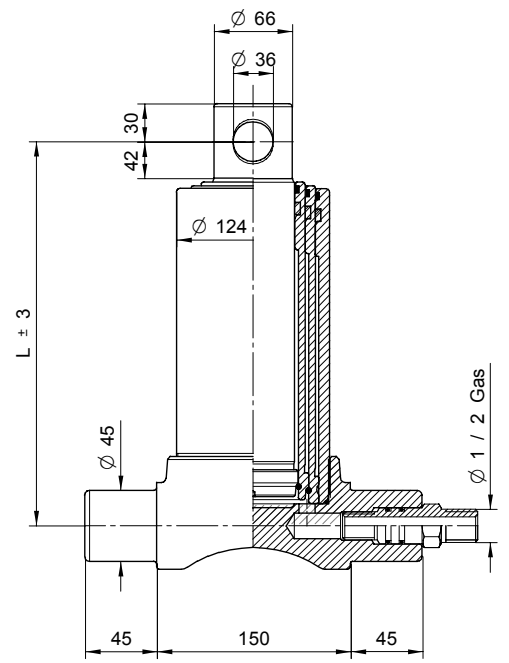

CILINDRI TELESCOPICI CON 3 SFILATE
TELESCOPIC CYLINDERS WITH 3 EXTENSIONS

TELESZKÓPOS MUNKAHENGER 3 TAGÚ
TELESKOPZYLINDER MIT 3 VERLÄNGERUNGEN

PESO TOT. RIBALTABILE 16,5 Ton. a 180 Bar

TOTAL WEIGHT TIP-UP 16,5 Ton. 180 Bar

ÖSSZTEHERBÍRÁS 16,5 TONNA 180 BAR MELLETT

GESAMTGEWICHT KIPPANHÄNGER 16,5 Ton. 180 Bar

TIPO TYPE TÍPUS	DISEGNO - DRAWING RAJZ - ZEICHNUNG	CORSA - STROKE LÖKET - HUB	Ø SFILATE mm Ø EXPANSIONS mm Ø TAGOK mm Ø STUFEN mm					L	L.sfilata - L. extension Tagok hossza - L.stufen	Peso - Kg - Weight		Volume oil Lt. Amount of oil Lt. Olajmennyiség - Liter Ölínhalt Lt.
			68 TON. 6,5	88 TON. 10,9	107 TON. 16,1	126 TON. 22,4	145 TON. 19,7			F	S	
4536	3446	1273		●	●	●		570	500	55	57	12
4538	3440	1483		●	●	●		640	570	61	63	13,8
4539	3466	2093		●	●	●		870	800	81	83	20

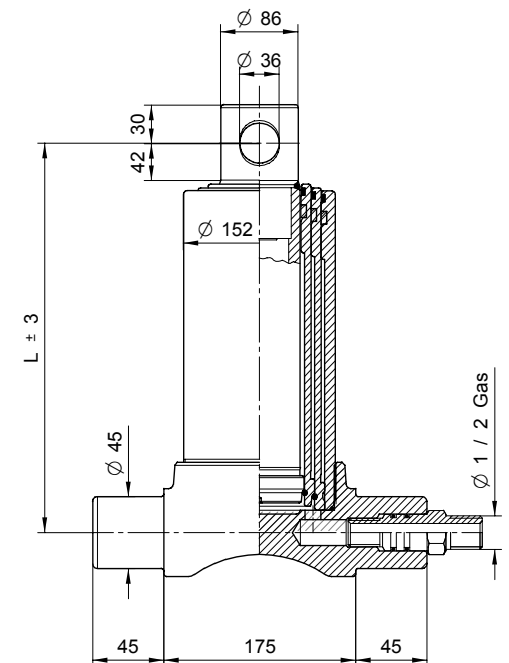

PRESSIONE MAX. DI ESERCIZIO 180 BAR - MAXIMÁLIS NYOMÁS 180 BAR
WORKING MAX. PRESSURE 180 BAR - MAX. BETRIEBSDRUCK 180 BAR

ALSÓ CSAPOS MUNKAHENGEREK



KKT

CILINDRI TELESCOPICI CON 4 SFILATE
TELESCOPIC CYLINDERS WITH 4 EXTENSIONS

TELESZKÓPOS MUNKAHENGER 4 TAGÚ
TELESKOPZYLINDER MIT 4 VERLÄNGERUNGEN

PESO TOT. RIBALTABILE 7 Ton. a 180 Bar
ÖSSZTEHERBÍRÁS 7 TONNA 180 BAR MELLETT

TOTAL WEIGHT TIP-UP 7 Ton. 180 Bar
GESAMTGEWICHT KIPPÄNHÄNGER 7 Ton. 180 Bar

TIPO TYPE TÍPUS TYP	DISEGNO - DRAWING RAJZ - ZEICHNUNG	CORSA - STROKE LÖKET - HUB	Ø SFILATE mm Ø EXPANSIONS mm Ø TAGOK mm Ø STUFEN mm					L	L.sfilata - L. extension Tagok hossza - L.stufen	Peso - Kg - Weight		Volume oil Lt. Amount of oil Lt. Olajmennyiség - Liter Ölínhalt Lt.
			46 TON. 2,9	61 TON. 5,2	76 TON. 8,1	91 TON. 11,7	107 TON. 16,1			F	S	
3561	8571	590	●	●	●	●		270	220	19	20,5	2,4
3562	10157	640	●	●	●	●		290	240	19,5	21	2,7
3563	10158	790	●	●	●	●		320	270	20,5	22	3,2
3564	10159	910	●	●	●	●		350	300	23,5	25	3,6
3565	4867	1060	●	●	●	●		385	335	25,5	27	4,3
3566	4868	1190	●	●	●	●		420	370	27,5	29	4,7
3567	4869	1390	●	●	●	●		470	420	31	32,5	6
3568	4870	1710	●	●	●	●		550	500	35,5	37	6,7
3569	4871	1990	●	●	●	●		620	570	39	40,5	7,9

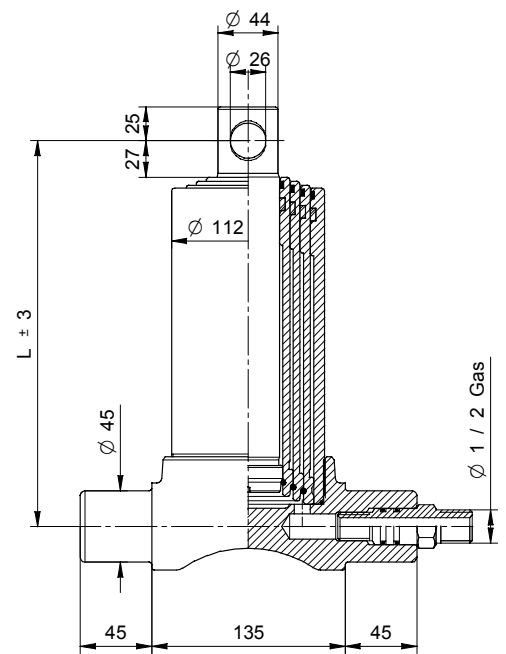

CILINDRI TELESCOPICI CON 4 SFILATE
TELESCOPIC CYLINDERS WITH 4 EXTENSIONS

TELESZKÓPOS MUNKAHENGER 4 TAGÚ
TELESKOPZYLINDER MIT 4 VERLÄNGERUNGEN

PESO TOT. RIBALTABILE 10 Ton. a 180 Bar
ÖSSZTEHERBÍRÁS 10 TONNA 180 BAR MELLETT

TOTAL WEIGHT TIP-UP 10 Ton. 180 Bar
GESAMTGEWICHT KIPPANHÄNGER 10 Ton. 180 Bar

TIPO TYPE TÍPUS TYP	DISEGNO - DRAWING RAJZ - ZEICHNUNG	CORSA - STROKE LÖKET - HUB	Ø SFILATE mm Ø EXPANSIONS mm Ø TAGOK mm Ø STUFEN mm					L	L.sfilata - L. extension Tagok hossza - L.stufen	Peso - Kg - Weight		Volume oil Lt. Amount of oil Lt. Olajmennyiség - Liter Ölínhalt Lt.
			46 TON. 2,9	61 TON. 5,2	76 TON. 8,1	91 TON. 11,7	107 TON. 16,1			F	S	
3541	3417	670		●	●	●	●	297	240	25	26,5	4
3542	3418	830		●	●	●	●	337	280	28,5	30	5
3543	3419	950		●	●	●	●	367	310	30	31,5	5,6
3544	3420	1050		●	●	●	●	392	335	32	33,5	6,2
3545	3421	1190		●	●	●	●	427	370	34,5	36	7
3546	3422	1290		●	●	●	●	452	395	37,5	39	7,5
3547	3423	1510		●	●	●	●	507	450	41,5	43	8,8
3548	3424	1710		●	●	●	●	557	500	45	46,5	10
3549	3425	1990		●	●	●	●	627	570	49,5	51	11

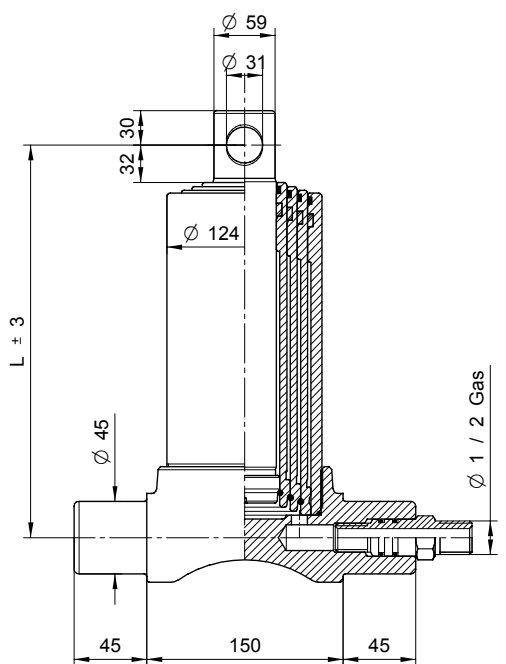

PRESSIONE MAX. DI ESERCIZIO 180 BAR - MAXIMÁLIS NYOMÁS 180 BAR
WORKING MAX. PRESSURE 180 BAR - MAX. BETRIEBSDRUCK 180 BAR

CILINDRI TELESCOPICI CON 4 SFILATE
TELESCOPIC CYLINDERS WITH 4 EXTENSIONS

TELESZKÓPOS MUNKAHENGER 4 TAGÚ
TELESKOPZYLINDER MIT 4 VERLÄNGERUNGEN

PESO TOT. RIBALTABILE 14 Ton. a 180 Bar
ÖSSZTEHERBÍRÁS 1 TONNA 180 BAR MELLETT

TOTAL WEIGHT TIP-UP 14 Ton. 180 Bar
GESAMTGEWICHT KIPPÄNHÄNGER 14 Ton. 180 Bar

TIPO TYPE TÍPUS	DISEGNO - DRAWING RAJZ - ZEICHNUNG	CORSA - STROKE LÖKET - HUB	Ø SFILATE mm Ø EXPANSIONS mm Ø TAGOK mm Ø STUFEN mm					L	L.sfilata - L. extension Tagok hossza - L. stufen	Peso - Kg - Weight		Volume olio Lt. Amount of oil Lt. Olajmennyiség - Liter Ölínhalt Lt.
			68 TON. 6,5	88 TON. 10,9	107 TON. 16,1	126 TON. 22,4	145 TON. 29,7			F	S	
										F	S	
4540	3478	1980	●	●	●	●		645	570	75,5	77	15,6
4541	3448	1040	●	●	●	●		410	335	48	49,5	8,3
4542	3449	1220	●	●	●	●		455	380	53,5	55	9,7
4543	3450	1500	●	●	●	●		525	450	61,5	63	12
4544	3451	1700	●	●	●	●		575	500	67,5	69	13,5

CILINDRI TELESCOPICI CON 4 SFILATE
TELESCOPIC CYLINDERS WITH 4 EXTENSIONS

TELESZKÓPOS MUNKAHENGER 4 TAGÚ
TELESKOPZYLINDER MIT 4 VERLÄNGERUNGEN

PESO TOT. RIBALTABILE 20 Ton. a 180 Bar
ÖSSZTEHERBÍRÁS 0 TONNA 180 BAR MELLETT

TOTAL WEIGHT TIP-UP 20 Ton. 180 Bar
GESAMTGEWICHT KIPPÄNHÄNGER 20 Ton. 180 Bar

TIPO TYPE TÍPUS	DISEGNO - DRAWING RAJZ - ZEICHNUNG	CORSA - STROKE LÖKET - HUB	Ø SFILATE mm Ø EXPANSIONS mm Ø TAGOK mm Ø STUFEN mm					L	L.sfilata - L. extension Tagok hossza - L. stufen	Peso - Kg - Weight		Volume olio Lt. Amount of oil Lt. Olajmennyiség - Liter Ölínhalt Lt.
			68 TON. 6,5	88 TON. 10,9	107 TON. 16,1	126 TON. 22,4	145 TON. 29,7			F	S	
										F	S	
4570	9806	1030		●	●	●	●	430	335	55	57	11,7
4571	9808	970		●	●	●	●	415	320	50	52	11,5
4572	9811	1210		●	●	●	●	475	380	60	62	13,7
4545	3452	1490		●	●	●	●	545	450	67	69	16,8
4546	3453	1690		●	●	●	●	595	500	74	76	19
4547	3454	1970		●	●	●	●	665	570	82	84	22,2
4590	13624	2510		●	●	●	●	825	730	100	102	30

PRESSIONE MAX. DI ESERCIZIO 180 BAR - MAXIMÁLIS NYOMÁS 180 BAR
WORKING MAX. PRESSURE 180 BAR - MAX. BETRIEBSDRUCK 180 BAR

ALSÓ CSAPOS MUNKAHENGEREK



KKT

CILINDRI TELESCOPICI CON 5 SFILATE
TELESCOPIC CYLINDERS WITH 5 EXTENSIONS

TELESZKÓPOS MUNKAHENGER 5
TELESKOPZYLINDER MIT 5 VERLÄNGERUNGEN

PESO TOT. RIBALTABILE 8 Ton. a 180 Bar
ÖSSZTEHERBÍRÁS 8 TONNA 180 BAR MELLETT

TOTAL WEIGHT TIP-UP 8 Ton. 180 Bar
GESAMTGEWICHT KIPPÄNHÄNGER 8 Ton. 180 Bar

TIPO TYPE TÍPUS TYP	DISEGNO - DRAWING RAJZ - ZEICHNUNG	CORSA - STROKE LÖKET - HUB	Ø SFILATE mm Ø EXPANSIONS mm Ø TAGOK mm Ø STUFEN mm					L	L.sfilata - L. extension Tagok hossza - L.stufen	Peso - Kg - Weight		Volume oil Lt. Amount of oil Lt. Olajmennyiség - Liter Ölínhalt Lt.
			46 TON. 2,9	61 TON. 5,2	76 TON. 8,1	91 TON. 11,7	107 TON. 16,1			F	S	
										F	S	
3550	3426	690	●	●	●	●	●	265	210	22	23,5	3,5
3591	10128	840	●	●	●	●	●	295	240	23,5	25	4,5
3592	10127	1040	●	●	●	●	●	335	280	27,5	29	5
3593	10126	1190	●	●	●	●	●	365	310	29,5	31	6
3594	10125	1490	●	●	●	●	●	425	370	33,5	35	7,5
3595	10124	2140	●	●	●	●	●	555	500	43,5	45	10,8
3596	10123	2490	●	●	●	●	●	625	570	49	50,5	12,4
3597	10122	1315	●	●	●	●	●	390	335	30,5	32	7
3598	10120	765	●	●	●	●	●	280	225	23	24,5	3,9
3599	10119	1850	●	●	●	●	●	505	450	39	40,5	9,5

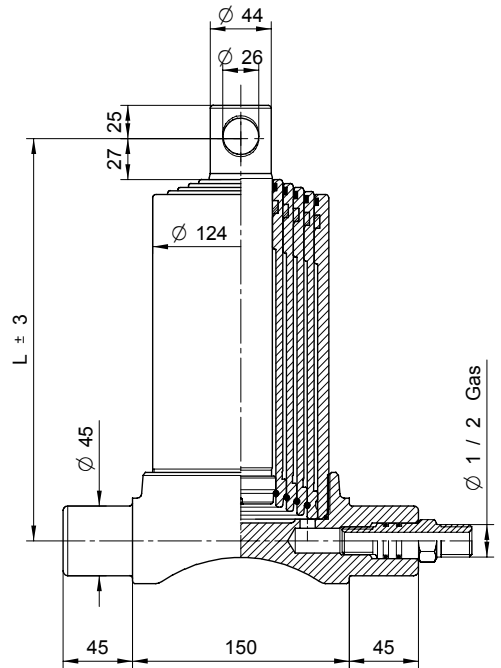

CILINDRI TELESCOPICI CON 5 SFILATE
TELESCOPIC CYLINDERS WITH 5 EXTENSIONS

TELESZKÓPOS MUNKAHENGER 5 TAGÚ
TELESKOPZYLINDER MIT 5 VERLÄNGERUNGEN

PESO TOT. RIBALTABILE 10 Ton. a 180 Bar
ÖSSZTEHERBÍRÁS 10 TONNA 180 BAR MELLETT

TOTAL WEIGHT TIP-UP 10 Ton. 180 Bar
GESAMTGEWICHT KIPPANHÄNGER 10 Ton. 180 Bar

TIPO TYPE TÍPUS TYP	DISEGNO - DRAWING RAJZ - ZEICHNUNG	CORSA - STROKE LÖKET - HUB	Ø SFILATE mm Ø EXPANSIONS mm Ø TAGOK mm Ø STUFEN mm					L	L.sfilata - L. extension Tagok hossza - L.stufen	Peso - Kg - Weight		Volume oil Lt. Amount of oil Lt. Olajmennyiség - Liter Ölínhalt Lt.
			61 TON. 5,2	76 TON. 8,1	91 TON. 11,7	107 TON. 16,1	126 TON. 22,4			F	S	
										F	S	
3551	3427	980	●	●	●	●	●	335	270	39	40,5	7,5
3552	3428	1230	●	●	●	●	●	385	320	44,5	46	9
3553	3429	1480	●	●	●	●	●	435	370	51,5	53	11
3554	3430	1880	●	●	●	●	●	515	450	60	61,5	13,5
3555	3431	2130	●	●	●	●	●	565	500	65,5	67	15,5
3556	10156	2480	●	●	●	●	●	635	570	73,5	75	18
3557	8646	830	●	●	●	●	●	305	240	35,5	37	6,5

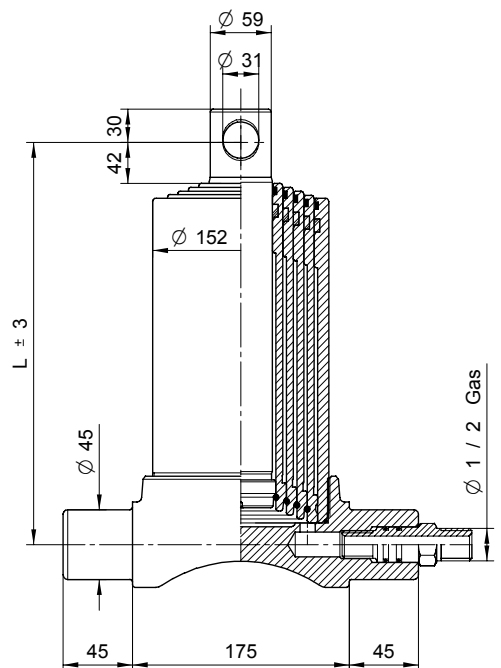

PRESSIONE MAX. DI ESERCIZIO 180 BAR - MAXIMÁLIS NYOMÁS 180 BAR
WORKING MAX. PRESSURE 180 BAR - MAX. BETRIEBSDRUCK 180 BAR

PIEDE DI APPOGGIO CON RITORNO A MOLLA
SUPPORT CYLINDER WITH SPRING RETURN

LETALPALÓ HENGER RUGÓ VISSZAHÚZÁSSAL
AUFLAGEZYLINDER MIT FEDERRÜCKZUG

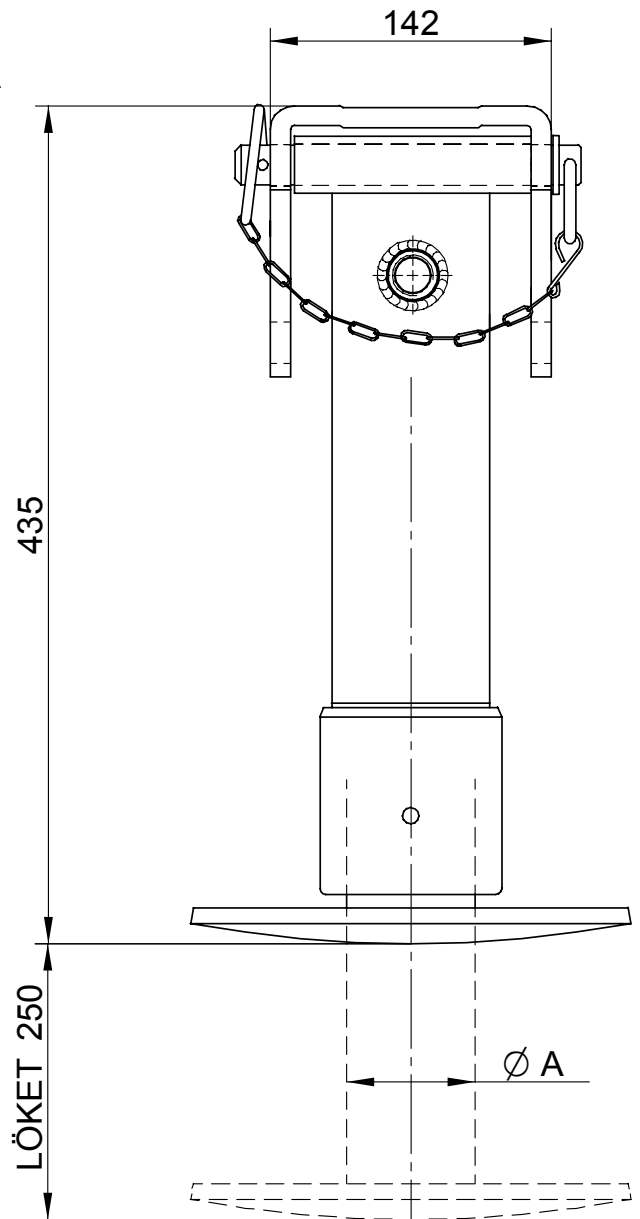
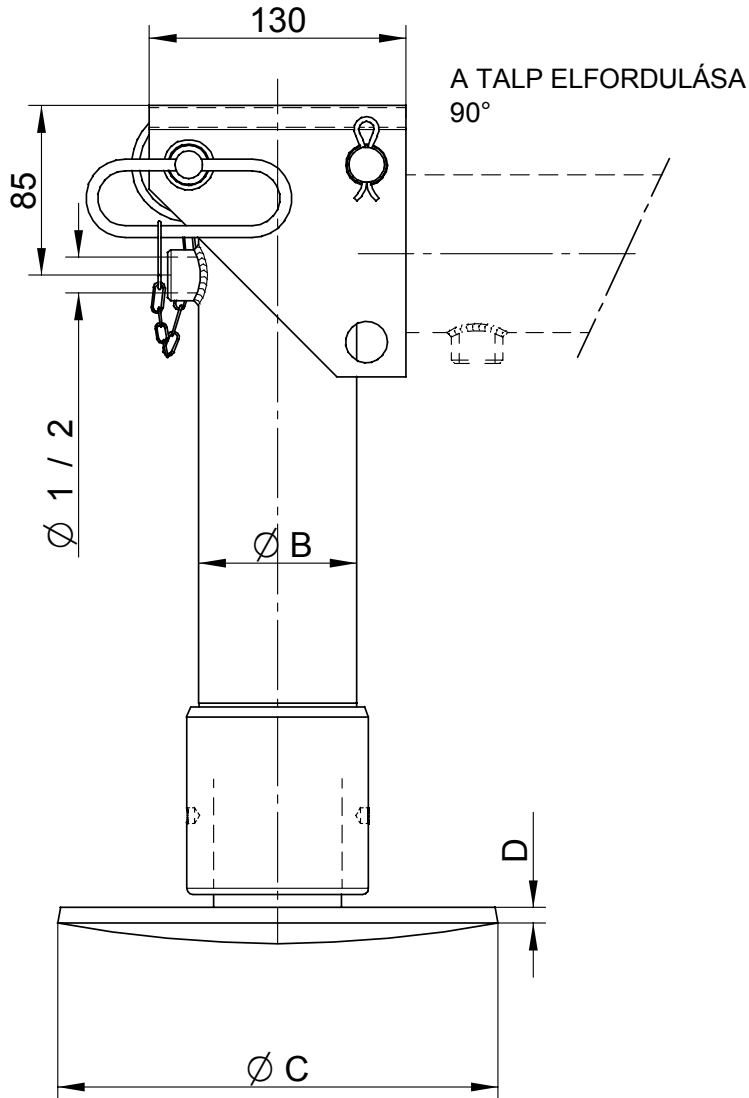

☞ STELO CROMATO – PISTON ROD CHROMIUM – KRÓMOZOTT ACÉL – STIEL CHROMAT

PRESSIONE MAX. DI ESERCIZIO 180 BAR
WORKING MAX. PRESSURE 180 BAR

MAXIMÁLIS NYOMÁS 180 BAR
MAX. BETRIEBSDRUCK 180 BAR

TIPO TYPE TÍPUS TYP	DIMENSIONI mm. MÉRETEK mm. DIMENSIONS mm. ABMESSUNGEN mm.				CORSA STROKE LÖKET HUB mm.	VOLUME OLIO AMOUNT OIL TÉRFOGAT ÖLINHALT Lt.	PESO WEIGHT TÖMEG GEWICHT KG.	PORTATA ton CAPACITY ton TEHERBÍRÁS ton BALASTBARKEIT ton	
	A	B	C	D				Bar 100	Bar 180
3520/65	65	80	160	8	250	0,8	17	3,3	5,9
3530/85	85	110	220	12	250	1,5	23	5,7	10,2

LETALPALÓ MUNKAHENGEREK ÉS FÉKMUNKAHENGER



PIEDINI STABILIZZATORI DOPPIO EFFETTO DOUBLE ACTING STABILIZER CYLINDERS

KETTŐS MŰKÖDÉSŰ LETALPALÓ DOPPELTWIRKENDE STÜTZZYLINDER

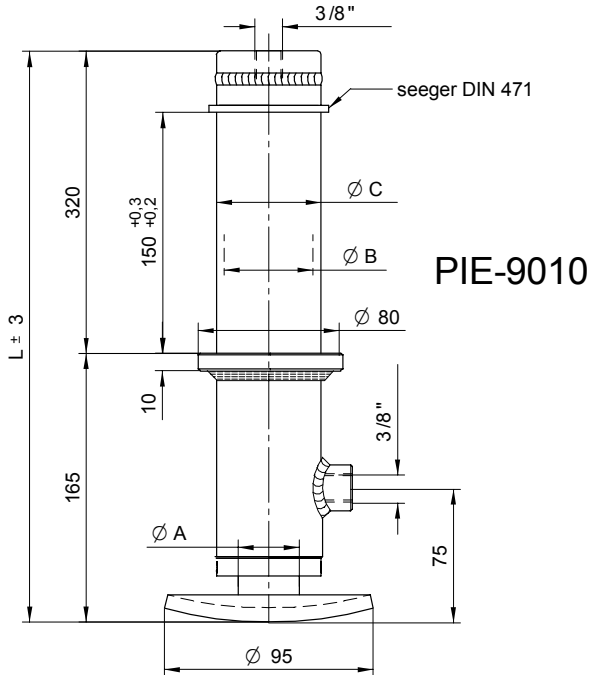

PIE-9010

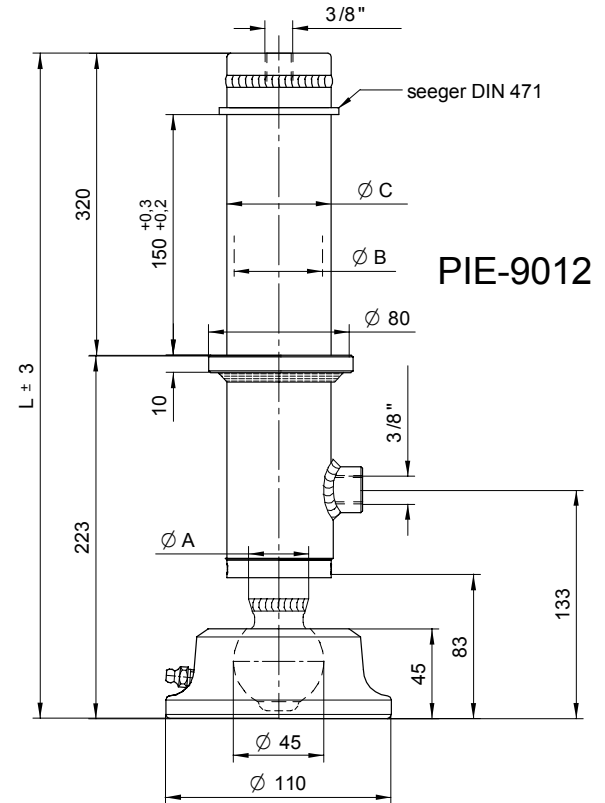

PIE-9012

STELO CROMATO – PISTON ROD CHROMIUM
KRÓMOZOTT ACÉL – STIEL CHROMAT



TIPO TYPE TÍPUS TYP	DIMENSIONI mm. MÉRETEK mm. DIMENSIONS mm. ABMESSUNGEN mm.				CORSA STROKE LÖKET HUB mm.	VOLUME OLIO AMOUNT OIL TÉRFOGAT ÖLINHALT Lt.	PESO WEIGHT TÖMEG GEWICHT KG.	PORTATA Kg. CAPACITY Kg. TEHERBÍRÁS Kg. BALASTBARKEIT Kg.	
	ØA	ØB	ØC	L				Bar 100	Bar 180
PIE-9010	35	50	60	485	325	0,7	7,5	1950	3500
PIE-9012	35	50	60	543	325	0,7	9	1950	3500

CILINDRO FRENO CON RITORNO A MOLLA BRAKE CYLINDER WITH SPRING RETURN

FÉKHENGER RUGÓVISSZAHÚZÁSSAL BREMSZYLINDER MIT FEDERRÜCKZUG

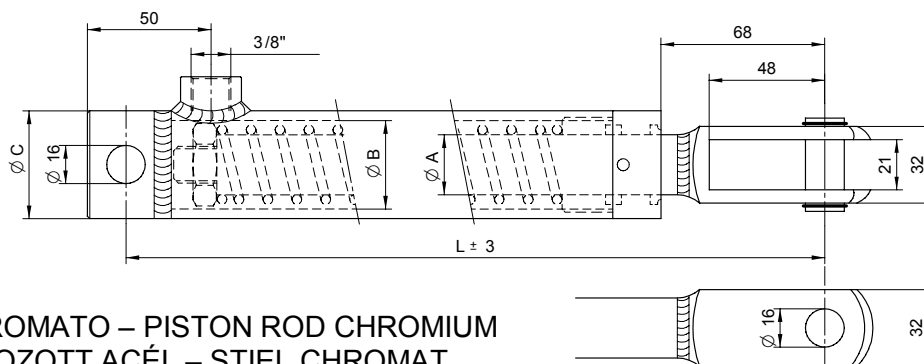

STELO CROMATO – PISTON ROD CHROMIUM
KRÓMOZOTT ACÉL – STIEL CHROMAT



TIPO TYPE TÍPUS TYP	DIMENSIONI mm. MÉRETEK mm. DIMENSIONS mm. ABMESSUNGEN mm.				CORSA STROKE LÖKET HUB mm.	VOLUME OLIO AMOUNT OIL TÉRFOGAT ÖLINHALT Lt.	PESO WEIGHT TÖMEG GEWICHT KG.	PORTATA Kg. CAPACITY Kg. TEHERBÍRÁS Kg. BALASTBARKEIT Kg.	
	ØA	ØB	ØC	L				Bar 100	Bar 180
2717	25	35	45	290	80	0,04	3	560	1000
2718	25	35	45	365	120	0,06	4	560	1000

SUPPORTI PER CILINDRI
BRACKETS FOR CYLINDERS

MUNKAHANGERHEZ TARTÓ
HALTERUNGEN FÜR ZYLINDER

NORMÁL

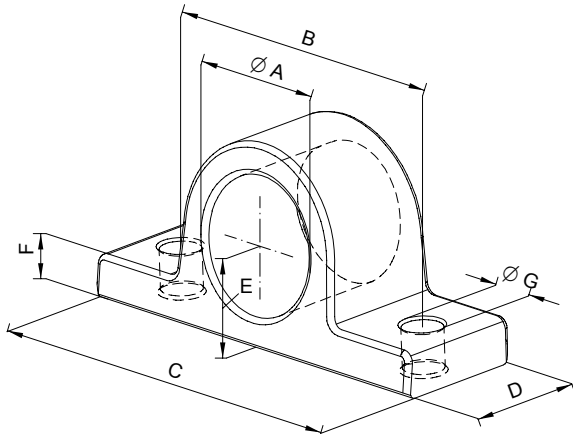

TIPO . . / I

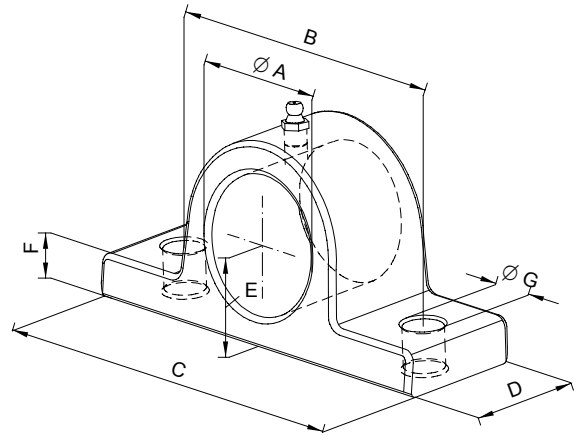

Materiale: Acciaio stampato UNI Fe 510 - Material: pressed Steel UNI Fe 510 - Anyag: kovácsolt acél UNI Fe 510 - Werkstoff: Prepstahl UNI Fe 510

TIPO TÍPUS TYPE TYP	DIMENSIONI D'INGOMBRO - DIMENSION - MÉRETEK - ABMESSUNGEN								PESO Kg TÖMEG Kg WEIGHT Kg GEWICHT Kg
	Ø A	B	C	D	E	F	Ø G		
Ø 35	35,5	95	130	45	30	12	13		1
Ø 40	40,5	105	140	45	33	15	15		1,2
Ø 45	45,5	105	140	45	33	15	15		1,2
Ø 50	50,5	120	155	50	37	17	15		1,5
Ø 55	55,5	120	155	55	37	17	15		1,5

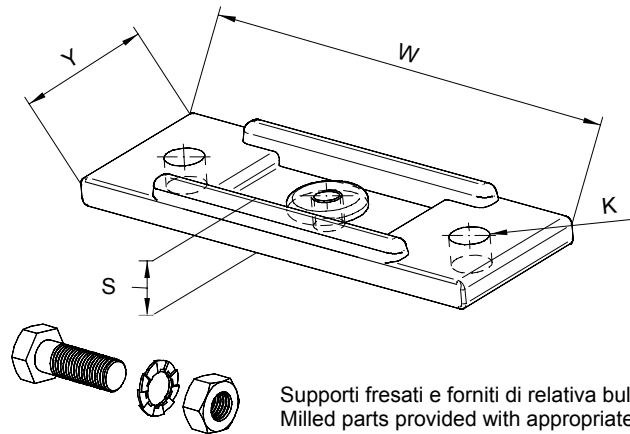
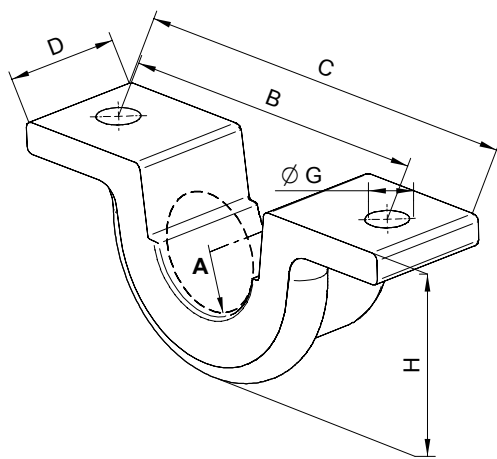

Supporti fresati e forniti di relativa bulloneria.
Milled parts provided with appropriate bolts and nuts.

Gefräste Teile mit entsprechenden Schrauben

Materiale: Acciaio stampato UNI Fe 510 - Material: pressed Steel UNI Fe 510 - Anyag: kovácsolt acél UNI Fe 510 - Werkstoff: Prepstahl UNI Fe 510

TIPO TÍPUS TYPE TYP	DIMENSIONI D'INGOMBRO - DIMENSION - MÉRETEK - ABMESSUNGEN										PESO Kg TÖMEG Kg WEIGHT Kg GEWICHT Kg
	Ø A	B	C	D	Ø G	H	W	Y	Ø K	S	
Ø40-AP	40,5	112	140	40	13	62	140	40	13	8	1
Ø45-AP	45,5	112	140	40	13	62	140	40	13	8	1,2
Ø50-AP	50,5	115	185	60	13	82	150	56	13	17	2,5
Ø55-AP	56	115	190	60	13	86	150	56	13	17	2,6
Ø70-AP	71	148	210	60	13	100	170	60	13	17	3,6

CULLE PER ANCORAGGIO MARTINETTI
CRADLES FOR CYLINDERS

MUNKAHENGERHEZ BÖLCSŐ
KARDANRING FÜR ZYLINDER

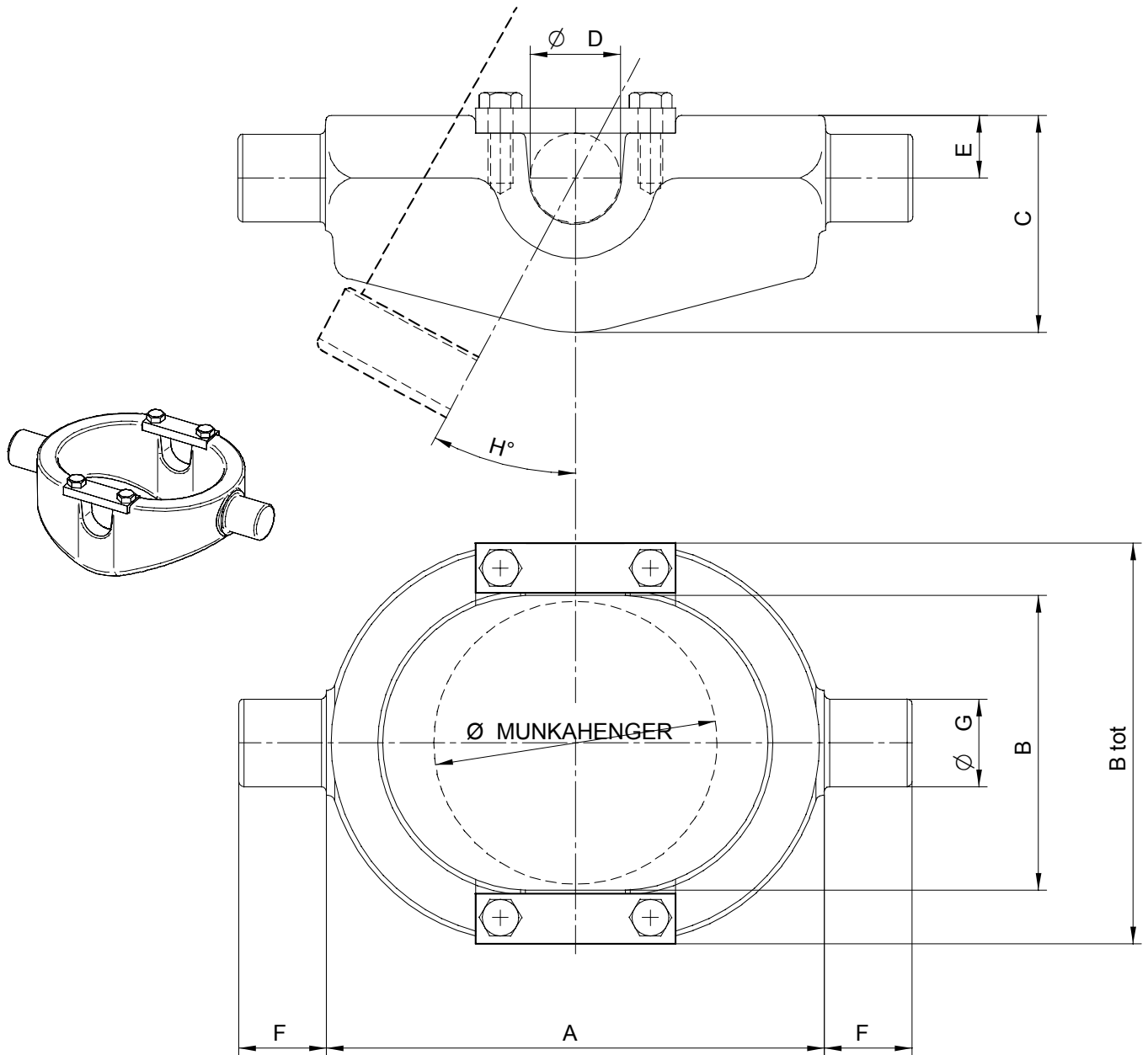

Materiale: Acciaio stampato UNI Fe 510 - Material: pressed Steel UNI Fe 510 - Anyag: Kovácsolt acél UNI Fe 510 - Werkstoff: Prepstahl UNI Fe 510

TIPO TÍPUS TYPE TYP	DIMENSIONI – MÉRETEK – DIMENSIONS – ABMESSUNGEN										PORTATA Ton. TEHERBÍRÁS Ton. CAPACITY Ton. BELASTBARKEIT Ton.	PESO Kg TÖMEG Kg WEIGHT Kg GEWICHT Kg
	A	B	B tot.	C	$\varnothing D$	E	F	$\varnothing G$	H	$\varnothing M.H.$		
CULLA 1	200	120	160	77	35	25	35	35	32°	80/95	7 Ton.	5
CULLA 2	230	135	195	97	35	28	40	40	37°	112	10 Ton.	9
CULLA 3	230	155	215	107	40	31	40	40	30°	124	16 Ton.	10,5
CULLA 4	280	185	240	125	45	40	45	50	30°	150	20 Ton.	15

CULLE PER ANCORAGGIO MARTINETTI
CRADLES FOR CYLINDERS

MUNKAHENGERHEZ BÖLCSŐ
KARDANRING FÜR ZYLINDER

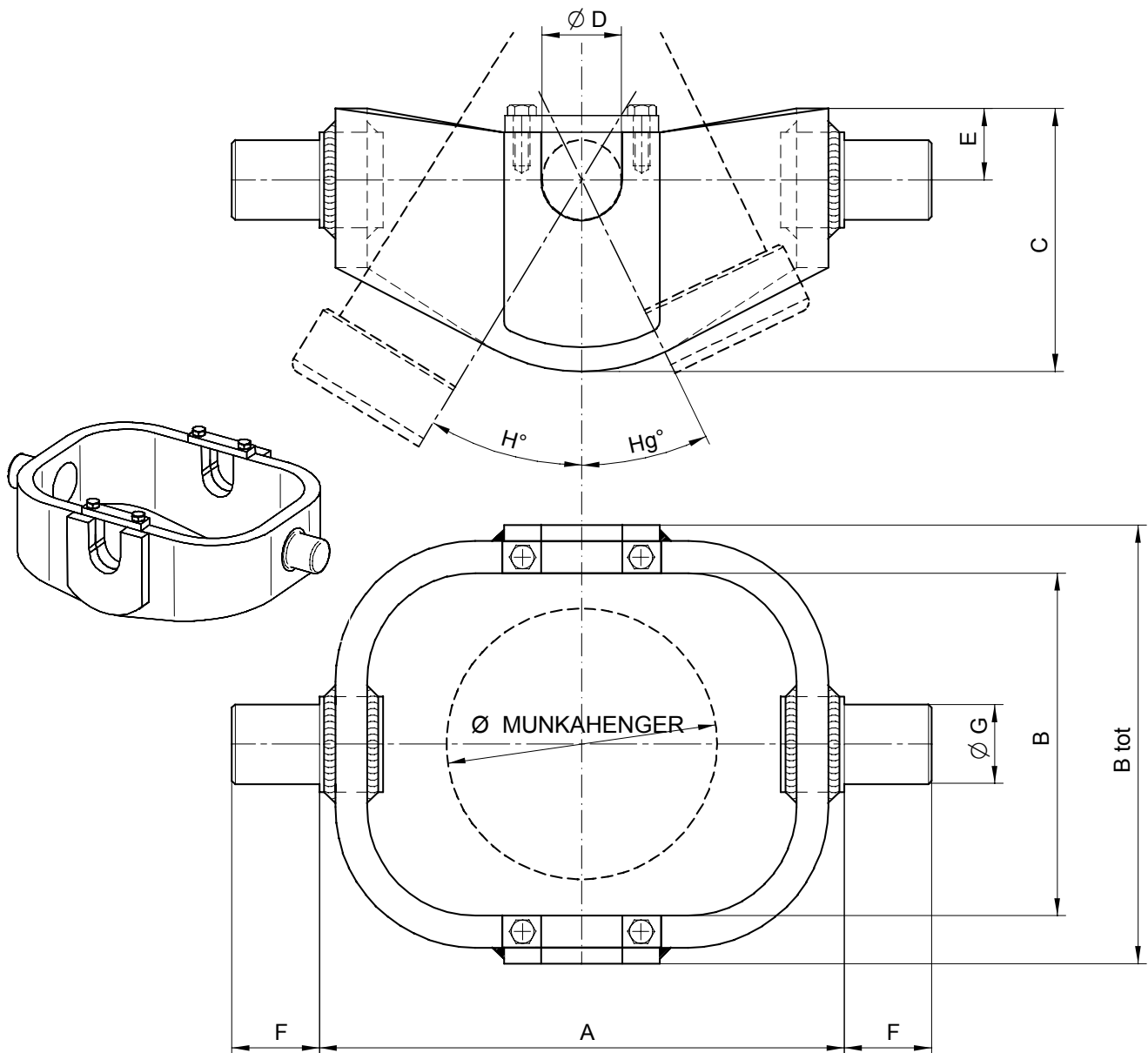

Materiale: Acciaio Fe 430/C - Material: Steel Fe 430/C - Anyag: Kovácsolt acél Fe 430/C - Werkstoff: Preprestahl Fe 430/C

TIPO TÍPUS TYPE TPY	DIMENSIONI – MÉRETEK – DIMENSIONS – ABMESSUNGEN											PORTATA Ton. TEHERBÍRÁS Ton. CAPACITY Ton. BELASTBARKEIT Ton.	PESO Kg TÖMEG Kg WEIGHT Kg GEWICHT Kg
	A	B	B tot	C	Ø D	E	F	Ø G	H°	Hg°	ØM.H.		
CULLA 5	330	215	290	165	50	45	55	50	30°	26°	170	22 Ton.	22
CULLA 6	390	235	310	205	50	65	55	50	30°	23°	190	23 Ton.	29
CULLA 7	400	255	350	205	50	65	55	50	30°	25°	215	25 Ton.	32
CULLA 8	460	277	370	235	55	68	55	55	34°	27°	240	25 Ton.	52
CULLA 8A	540	277	380	300	70	85	55	70	40°	35°	240	35 Ton.	74
CULLA 9	540	312	395	300	70	85	55	70	36°	30°	270	38 Ton.	77
CULLA 10	540	342	425	300	70	85	55	70	32°	26°	300	38 Ton.	77

**ATTACCO A SFERA FILETTATO
BALL JOINT WITH THREAD**

**CSÉSZE MENETES BÖMBBEL
KUGELVERBINDUNG MIT GEWINDE**

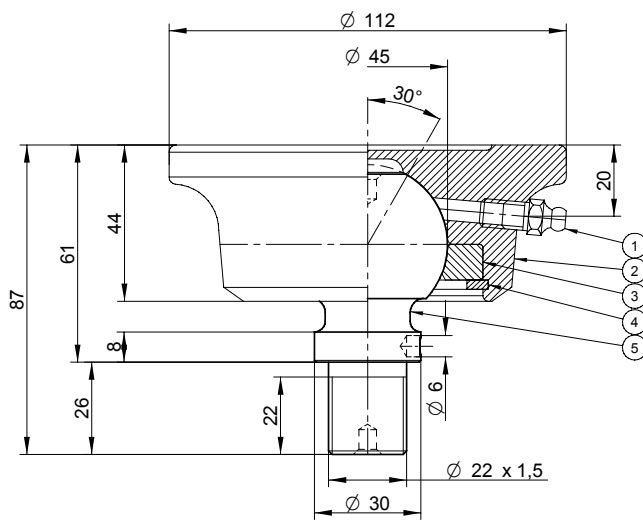

TIPO / TÍPUS / TYPE / TPY

Ø 45

PORTATA MAX 11 Ton.
MAX.TEHERBÍRÁS 11 TONNA
MAX CAPACITY 11 Ton.
MAX BALASTBARKEIT 11 Ton.

PESO – WEIGHT – TÖMEG – GEWICHT Kg. 3,2

CODICE / KÓD / CODE / KODE

80800000

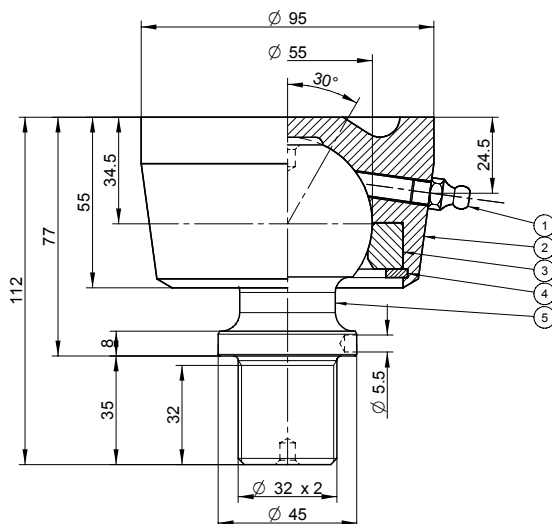

TIPO / TÍPUS / TYPE / TPY

Ø 55

PORTATA MAX 15 Ton.
MAX.TEHERBÍRÁS 15 TONNA
MAX CAPACITY 15 Ton.
MAX BALASTBARKEIT 15 Ton.

PESO – WEIGHT – TÖMEG – GEWICHT Kg. 4,3

CODICE / KÓD / CODE / KODE

80810000

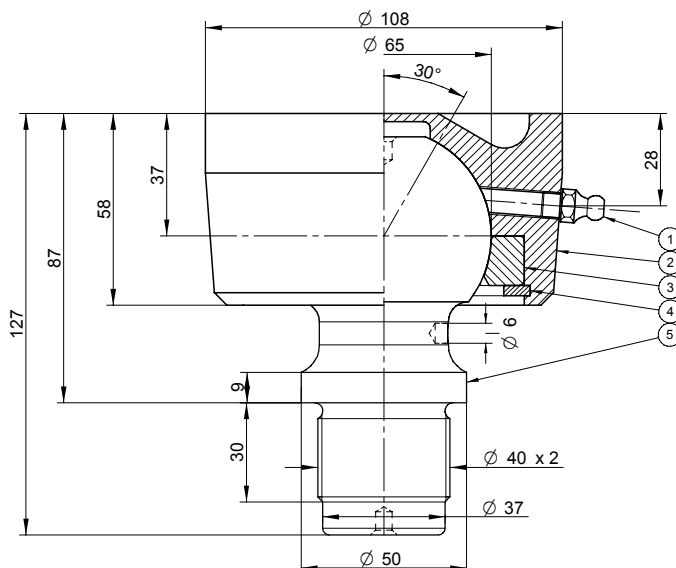

TIPO / TÍPUS / TYPE / TPY

Ø 65

PORTATA MAX 23 Ton.
MAX.TEHERBÍRÁS 23 TONNA
MAX CAPACITY 23 Ton.
MAX BALASTBARKEIT 23 Ton.

PESO – WEIGHT – TÖMEG – GEWICHT Kg. 4,8

CODICE / KÓD / CODE / KODE

80820000

ATTACCO A SFERA
BALL JOINT

CSÉSZE HEGESZTHETŐ GÖMBBEL
KUGELVERBINDUNG

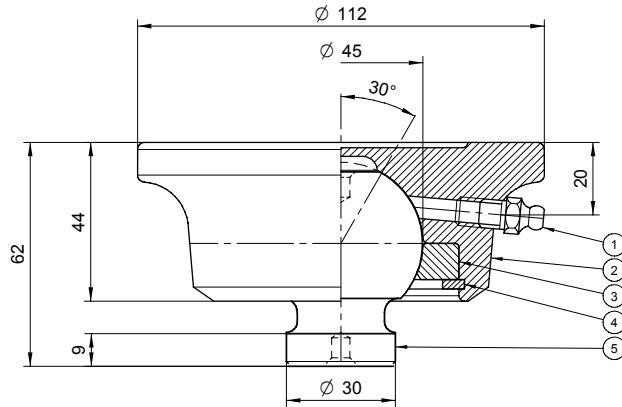

TIPO / TÍPUS / TYPE / TPY

Ø 45

PORTATA MAX 11 Ton.
MAX.TEHERBÍRÁS 11 TONNA
MAX CAPACITY 11 Ton.
MAX BALASTBARKEIT 11 Ton.

PESO – WEIGHT – TÖMEG – GEWICHT Kg. 2,2

CODICE / KÓD / CODE / KODE

78910000

TIPO / TÍPUS / TYPE / TPY

Ø 55

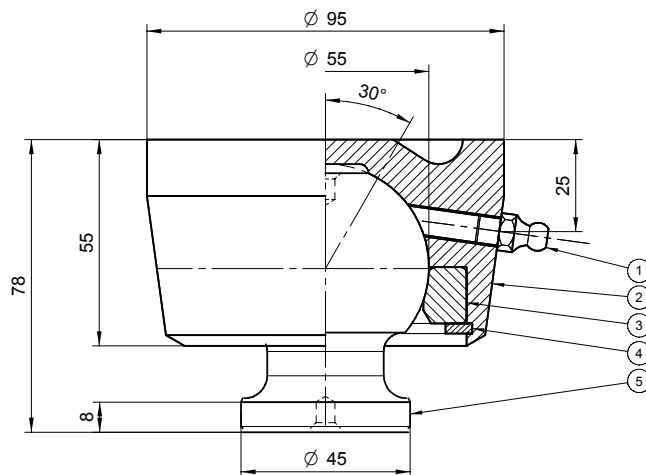

PORTATA MAX 15 Ton.
MAX.TEHERBÍRÁS 15 TONNA
MAX CAPACITY 15 Ton.
MAX BALASTBARKEIT 15 Ton.

PESO – WEIGHT – TÖMEG – GEWICHT Kg. 3

CODICE / KÓD / CODE / KODE

78920000

TIPO / TÍPUS / TYPE / TPY

Ø 65

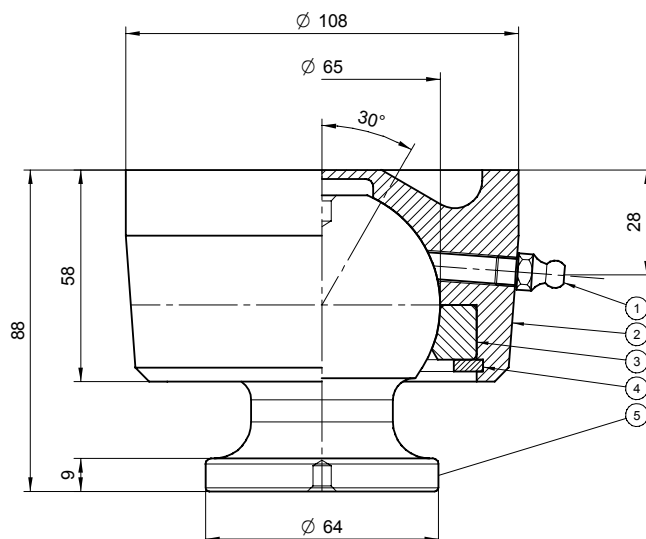

PORTATA MAX 23 Ton.
MAX.TEHERBÍRÁS 23 TONNA
MAX CAPACITY 23 Ton.
MAX BALASTBARKEIT 23 Ton.

PESO – WEIGHT – TÖMEG – GEWICHT Kg. 4

CODICE / KÓD / CODE / KODE

78930000